

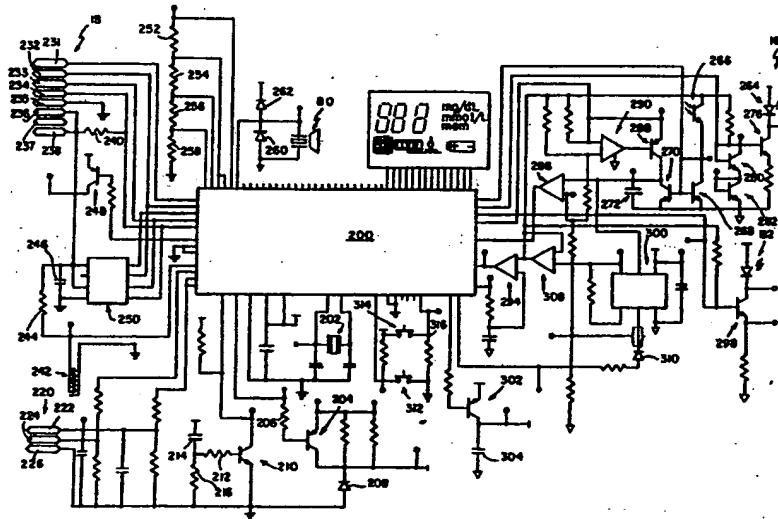

INTERNATIONAL APPLICATION PUBLISHED UNDER THE PATENT COOPERATION TREATY (PCT)

| | | |
|--|------------------|--|
| <p>(51) International Patent Classification ⁵ : G06F 15/00</p> | <p>A1</p> | <p>(11) International Publication Number: WO 92/15950 (43) International Publication Date: 17 September 1992 (17.09.92)</p> |
| <p>(21) International Application Number: PCT/US92/01631 (22) International Filing Date: 27 February 1992 (27.02.92) (30) Priority data: 661,889 27 February 1991 (27.02.91) US (71) Applicant: BOEHRINGER MANNHEIM CORPORATION [US/US]; 9115 Hague Road, P.O. Box 50528, Indianapolis, IN 46250-0528 (US). (72) Inventors: ARBUCKLE, Steven, R. ; 6435 Breamore Road, Indianapolis, IN 46220 (US). GRANT, Michael, E. ; 1500 Dover Highway, P.O. Box 1929, Saint Point, ID 83864 (US). RIEDEL, Richard ; 10012 Holaday Drive, Carmel, IN 46032 (US). HAMMER, Roger, L. ; 427 North Adam Street, Knightstown, IN 46148 (US).</p> | | <p>(74) Agents: CONARD, Richard, D. et al.; Barnes & Thornburg, 1313 Merchants Bank Building, 11 South Meridian Street, Indianapolis, IN 46204 (US). (81) Designated States: AT (European patent), BE (European patent), CH (European patent), DE (European patent), DK (European patent), ES (European patent), FR (European patent), GB (European patent), GR (European patent), IT (European patent), JP, LU (European patent), MC (European patent), NL (European patent), SE (European patent). Published <i>With international search report.</i></p> |

(54) Title: METHOD OF COMMUNICATING WITH MICROCOMPUTER CONTROLLED INSTRUMENTS



(57) Abstract

A method of communicating with one or more microcomputer (200) controlled instruments (10) for determining the concentration of a medically significant component of a body fluid. Each instrument (10) includes a port (220) through which instructions and data can be received from, and transmitted to, an external device. The method comprises the steps of transmitting to each instrument (10) an attention protocol for advising each instrument (10) that a further instruction is to be transmitted, transmitting one of a global address to all of such instruments (10) and an address unique to one of such instruments (10), and transmitting an instruction to all of the instruments (10) or to the above-mentioned one instrument (10).

FOR THE PURPOSES OF INFORMATION ONLY

Codes used to identify States party to the PCT on the front pages of pamphlets publishing international applications under the PCT.

| | | | | | |
|----|--------------------------|----|---------------------------------------|----|--------------------------|
| AT | Austria | FI | Finland | MI | Mali |
| AU | Australia | FR | France | MN | Mongolia |
| BB | Barbados | GA | Gabon | MR | Mauritania |
| BE | Belgium | GB | United Kingdom | MW | Malawi |
| BF | Burkina Faso | GN | Guinea | NL | Netherlands |
| BG | Bulgaria | GR | Greece | NO | Norway |
| BJ | Benin | HU | Hungary | PL | Poland |
| BR | Brazil | IE | Ireland | RO | Romania |
| CA | Canada | IT | Italy | RU | Russian Federation |
| CF | Central African Republic | JP | Japan | SD | Sudan |
| CG | Congo | KP | Democratic People's Republic of Korea | SE | Sweden |
| CH | Switzerland | KR | Republic of Korea | SN | Senegal |
| CI | Côte d'Ivoire | LJ | Liechtenstein | SU | Soviet Union |
| CM | Cameroon | LK | Sri Lanka | TD | Chad |
| CS | Czechoslovakia | LU | Luxembourg | TG | Togo |
| DE | Germany | MC | Monaco | US | United States of America |
| DK | Denmark | MG | Madagascar | | |
| ES | Spain | | | | |

Method of Communicating with Microcomputer Controlled Instruments

Technical Field

This invention relates to apparatus and methods
5 for reading the concentration of a medically significant
component of a biological fluid from a test strip.

Industrial Applicability

The invention is disclosed in the context of an
10 apparatus and a method for reading the concentration of
glucose in blood reacted on a test strip with a chemistry
with which the strip has previously been treated.

Background Art

15 The difficulty many people have with preparing
test strips treated with chemistries with bodily fluids
such as blood and urine is known. Many users of such
strips have poor eyesight owing to diabetes, to age, and
to other causes as well. Many users have reduced
20 dexterity or strength in their hands owing to age and to
other causes. Frequently these causes are the reasons
why these users are testing their bodily fluids for, for
example, glucose concentration to begin with.

The problems with such strips only begin with
25 dosing the strips with the bodily fluid or fluids to be
analyzed. The chemistries are reactants with the
medically significant component(s) of the fluids. These
reactants react with the medically significant
component(s) resulting typically in some colorimetric
30 indication of the concentration of the medically
significant component of the fluid. However, these
reactions continue, typically for extended times, until
all of the reactants have reacted. Consequently, it is
generally necessary to time the reaction of the medically
35 significant component with the strip chemistry so that a

-2-

colorimetric comparison of the reacted strip chemistry to a standard on a color chart can be made at some established time after the reaction is initiated by depositing the fluid on the strip. Otherwise, if the
5 reaction is not permitted to proceed long enough, or is permitted to proceed too long, the color corresponding to the extent of the reaction will not match the correct standard on the chart.

In addition to potential problems with how long
10 the chemistry on the strip and the medically significant component of the body fluid are permitted to react, there are problems with many of such chemistry systems with how much of the body fluid is applied to the strip, since incorrect amounts of the reactants may affect the
15 validity of the test as adversely as errors in the timing of the reaction. Either way, a false reading, sometimes with dire consequences, will result.

The present invention makes use of an endpoint chemistry system of the type described in U.S. Patent
20 4,929,545. The disclosure of U.S. Patent 4,929,545 is incorporated herein by reference. The advantages of an endpoint chemistry are clear. For the user who frequently has poor eyesight and/or manual dexterity, there is no need to be concerned about how long the
25 reaction has proceeded. The reaction reaches an endpoint in relatively short order after which there is no significant shift in the color of the reaction products on the strip. In addition, the architecture of the strip described in U.S.S.N. 07/661,788, filed February 27,
30 1991, IMPROVED TEST STRIP, naming as inventors McCroskey, Freitag, Smith, Dean, Secrest and Bouse, and assigned to Boehringer Mannheim Corporation, is such that the proper dose of the body fluid, the biologically significant component of which is to be reacted with the chemistry on
35 the strip, will always be available for the reaction.

-3-

Any excess is wicked away from the reaction site by the strip architecture. Thus, all the user need do is be sure enough of the bodily fluid is present at the reaction site on the strip to react with the chemistry with which the strip is treated. The disclosure of U.S.S.N. 07/661,788 is incorporated herein by reference.

Disclosure of the Invention

According to the invention, a method is provided for communicating with one or more microcomputer controlled instruments for determining the concentration of a medically significant component of a body fluid. Each instrument includes a port through which instructions and data can be received from, and transmitted to, an external device. The method comprises the steps of transmitting to each instrument an attention protocol for advising each instrument that a further instruction is to be transmitted, transmitting one of a global address to all of such instruments and an address unique to one of such instruments, and transmitting an instruction to all or to said one instrument.

Illustratively according to the invention the step of transmitting the attention protocol comprises either the step of transmitting a first attention protocol (if the instruments are activated and in a state in which they are capable of determining the concentration of the medically significant component) or the step of transmitting a second attention protocol (if the instruments are inactivated and not in a state in which they are capable of determining the concentration of the medically significant component).

Further illustratively according to the invention the step of transmitting an instruction comprises the step of transmitting one of a command and a request. The method further comprises the step of

-4-

transmitting a key for permitting the instrument or instruments addressed to respond to the command.

Additionally illustratively according to the invention the steps of transmitting a key and a command
5 together comprise the step of first transmitting the key for permitting the instrument or instruments addressed to receive the command and then transmitting the command for causing the instrument or instruments addressed to respond to the command.

10 Illustratively the instrument includes a programmable non-volatile memory and the instruction comprises instrument calibration information for storage in the non-volatile memory. Illustratively the method
15 further comprises the steps of reading the calibration information from the non-volatile memory, comparing that information to information contained in a volatile memory in the microcomputer, and generating an error message in response to an unfavorable comparison.

20 Brief Description of the Drawings

The invention may best be understood by referring to the following detailed description and accompanying drawings which illustrate the invention. In the drawings:

25 Figs. 1-8 illustrate exploded perspective views, from various different angles, of various components of an instrument constructed according to the present invention;

30 Fig. 9 illustrates a partly block and partly schematic circuit diagram of the electric circuit of the instrument illustrated in Figs. 1-8;

Fig. 10 illustrates a type of flow diagram useful in understanding the operation of the instrument illustrated in Figs. 1-8;

35 Fig. 11 illustrates a % remission versus time

-5-

curve useful in understanding the operation of the software of the instrument of Figs. 1-9;

Fig. 12 illustrates another % remission versus time curve useful in understanding the operation of the software of the instrument of Figs. 1-9; and

Fig. 13 illustrates an address and segment map for an LCD according to the present invention.

Mode For Carrying Out the Invention

Referring now to Figs. 1 and 8, an instrument according to the invention includes a case having a front portion 14, a rear portion 16, a key housing portion 18 and a strip carrier holder portion 20. A printed circuit board 22, the contents of which will be considered in more detail in the discussion of Fig. 9, is sandwiched generally between the front and rear portions 14, 16, respectively. Front portion 14 includes a relief 24 of generally trapezoidal configuration at the center of which is a generally circular opening 26. A generally right circular cylindrical stem 28 extends downwardly from the underside of front portion 14 beneath opening 26. This stem 28 slidably receives a stem 30 provided on the back of an ON/OFF button 32 of the same shape as relief 24. The lower end of stem 30 is split axially and somewhat frustoconical in configuration so that button 32 is captured in relief 24 when stem 30 is pushed into opening 26 until the split, frustoconical end 36 of stem 30 clears the bottom end 38 of stem 28. The portion of stem 30 above end 36 is somewhat longer than stem 28 so that some movement of button 32 vertically in relief 24 is possible.

Front casing portion 14 also includes a wall 40 inside of, and parallel with, a region 42 of an end wall thereof. Wall 40 includes a vertically extending groove 44 open at its bottom 46 and with a semicircular top 48.

-6-

A memory button 50 has ribs 52 on its back wall spaced apart slightly less than the width of groove 44. Button 50 excluding ribs 52 is slightly thicker than the space between wall 40 and region 42. The flexible resin construction of front portion 14 and a circular opening 54 of slightly larger diameter than button 50 in region 42 permits the wall 40 to flex away from region 42 as button 50 is forced into the space between them and snaps into place protruding through opening 54. A flange 56 on button 50 keeps it from going all the way through opening 54 and falling from front portion 14.

The front and rear portions 14, 16 include respective, cooperating, somewhat arcuate cutouts 60, 62 (Figs. 1, 6 and 8), for key housing portion 18. Key housing portion 18 is designed to receive an electronically readable information carrier, or key, 64 (Fig. 2) of the type described in U.S. Patent 5,053,199. The disclosure of U.S. Patent 5,053,199 is incorporated herein by reference. Front and rear portions 14, 16 also include cooperating cutouts 68, 70 (Figs. 1, 6 and 8) for receiving the strip carrier holder portion 20. Front portion 14 also includes a window 74 (Figs. 1 and 8) around which a liquid crystal display 76-supporting bezel 78 (Figs. 3 and 7) fits on the inside of front portion 14. Bezel 78 mounts the LCD 76 so as to be visible through window 74 and provides the necessary electrical connections 79 to LCD 76.

The back portion 16 of the case 12 also includes means for mounting a piezoelectric beeper transducer 80 (Fig. 6) and for providing electrical contact 81 thereto and a battery housing cutout 82 having a pivotally mounted door 84 for convenient insertion and removal of a six-volt battery 86.

The lips 88, 90 of front and back portions 14, 16, respectively, are complementarily configured to snap

-7-

together. As further insurance against their inadvertently coming apart, a self tapping screw 92 (Fig. 1) through back portion 16 and into a stem 94 molded on the inside of front portion 14 holds portions 14, 16 together. Screw 92 extends through a hole 96 provided therefor in printed circuit board 22, which, along with the configurations of the interiors of front and back portions 14, 16, holds board 22 in place.

The strip carrier holder portion 20 includes an outer case portion 100 provided with grooves 102 (Fig. 4) on its top and bottom surfaces to aid in gripping it and snapping it into and out of engagement with the front 14 and back 16 case portions. Case portion 100 is provided with an opening 104 for inserting chemistry strips 106, the remissions of which are to be read, into the instrument 10. The margins 108 of opening 104 are somewhat funnel-shaped to assist in insertion of the strips 106 into the instrument 10 in the correct orientation. A pair of somewhat pawl-shaped members 110 extend rearwardly of case portion 100 beneath opening 104. Members 110 define between them a slot 112 which opens into a somewhat equilateral triangular region 114 near their remote ends 116, then closes back to its slot configuration, and then opens into a somewhat funnel shape 118 adjacent the remote ends 116 of members 110. A strip carrier body 120 includes a lower web portion 122 along each of the opposite sides of which extend two guide ribs 124. Web portion 122 is only slightly thinner than slot 112 is for most of its length. Guide ribs 124 are spaced apart only slightly further than the vertical thickness of each of members 110. These dimensions permit strip carrier body 120 to be slid into the slot 112 defined between members 110. A triangular horizontal cross section projection 126 spaced an appropriate distance along web portion 122 on each side thereof

-8-

between guide ribs 124 cooperates with region 114 on case portion 100 to lock strip carrier body 120 between members 110.

5 Near its end remote from case portion 100, strip carrier body 120 includes a pair of horizontally projecting ears 130, each of which is provided with an elongated slot 132. Slots 132 extend generally transversely to the directions of motion of strips 106 as the strips are inserted into opening 104 and into the
10 strip carrier holder 20 and removed therefrom. A lift 134 includes a pair of vertically, oppositely extending trunnions 136 which engage in respective slots 132 to permit lift 134 to move away from strip carrier body 120 as a strip 106 to be read is inserted therebetween. Lift
15 134, in turn, includes a pair of horizontally extending ears 138 at its forward end opposite the end at which trunnions 136 are provided. Each ear 138 is provided with a vertically extending circular cross section hole
20 140. A high reflectance (remission) white tile 142 is provided with a pair of trunnions 144 by which it is pivotally attached, by insertion of trunnions 144 into respective holes 140, to lift 134. Directly across from
25 the point 146 at which white tile 142 projects through an opening 150 provided therefor in lift 134, strip carrier body 120 is provided with a slot 152. Strip carrier body 120 is also provided with another slot 154 between slot 152 and case portion 100, and with a frustoconical relief
30 156 (illustrated only in Fig. 1) on the side thereof opposite the side to which lift 134 is attached.

30 An optics assembly 160 (Figs. 1, 3 and 5) mounted on the printed circuit board 22 cooperates with the strip carrier holder portion 20. The cooperation of these two components negates any possible misalignment errors between the optics and the strips 106. This
35 cooperation is aided by the designs and tolerances of

-9-

some of the molded plastics parts from which the strip carrier holder portion 20 and optics assembly 160 are largely constructed. These designs and tolerances permit the components of the strip carrier holder portion 20 and optics assembly 160 which must be properly aligned for accurate reading of the reacted strips' 106s' remissions to align properly when the strip carrier holder portion 20 is assembled into the instrument case 12.

Optics assembly 160 includes an optics housing 162. Housing 162 houses a leaf spring 168 and, across from spring 168, a wall 170 against which the spring 168 forces the strip carrier body 120 to position it and its related components 134, 142 and a strip 106 carried thereby properly relative to the instrument 10's optics. A frustoconical projection (not illustrated) projecting toward spring 168 from wall 170 adjacent the inner end 171 of housing 162 engages relief 156 on strip carrier body 120 when strip carrier body 120 is correctly positioned in optics housing 162. A pair 174, 176 (Fig. 3) of transparent plastic prisms, molded as a single piece 177, are mounted on printed circuit board 22 in separate internal regions 178, 180, respectively, (Fig. 5) of housing 162. A light emitting diode 182 is mounted on board 22 and fitted into an LED adapter 184 which, in turn, is fitted into an LED socket 186 provided on housing 162. LED 182 is the initiation, or "upstream" end, of a glucose measurement channel 164.

Wall 170 is provided with a vertical slit opening 190 opposite the opening of socket 186 into housing 162. In the assembled optics assembly 160, this slit opening 190 is directly adjacent prism 174, the smaller of the two prisms provided by piece 177. In order to avoid receiving the direct reflected light from the reacted test chemistry on a strip 106, prism 174 is oriented at an angle to the surface of the strip 106

-10-

other than the angle of incidence of light from LED 182 onto, or the angle of reflection of light from LED 182 from, strip 106. Illustratively, prism 174 is oriented at an angle of about 77° to the surface of strip 106.

5 This increases the likelihood that light received by prism 174 is not direct reflected light, but rather ambient remission light, from the reacted chemistry on strip 106. This diffuse light is a better gauge than direct reflected light of the end point of the reaction

10 between the glucose in blood applied to strip 106 and the chemistry with which strip 106 is treated. Thus, this ambient remission light is a better gauge of the concentration of the glucose content of the blood.

Prism 176 is oriented directly adjacent a slit opening 191 through wall 170 in the assembled optics assembly 160. The problem of obtaining a diffuse or remission light component of the light reflected from strip 106 is not so great with the light entering prism 176 as it is with the light entering prism 174 because

20 the light entering prism 176 is used only to determine whether there is a strip in strip carrier body 120, and, if so, whether the strip is properly oriented with its chemistry immediately opposite opening 190 and prism 174. Since prism 176 is not in the chemistry reading channel

25 164, the remission reading from it is not so critical.

Both of prisms 174, 176 have curved faces facing strip 106. These curved faces function as lenses to focus the light remissions entering the prisms on the devices which detect these remissions. The lenses

30 incorporated into prisms 174, 176, in other words, have focal lengths equal to the distances from the lenses to their respective regions of interest on the strip 106 and also equal to the distances from the lenses to their respective detector devices.

35 Turning now to Fig. 9, the operation of

-11-

instrument 10 is controlled by a microcomputer (μc) 200 such as the NEC type $\mu\text{PD75P308}$ μc . All subsequent references herein to pin and terminal numbers and names will be to the pin and terminal numbers and names of the specific integrated circuits and other devices identified herein as exemplary. It is to be understood, however, that other integrated circuits may exist which are equally suited to provide the functions required by instrument 10. The clock for μc 200 is a 4.19 MHz crystal 202 which is coupled across terminals X1-X2 thereof. The terminals of crystal 202 are also coupled through respective 33pF capacitors to ground. The V_{DD} supply for μc 200 is provided by a PNP transistor 204 such as a BC858C, the base of which is coupled through a 62K Ω resistor 206 to terminal P4.1 of μc 200. The collector of transistor 204 is coupled to positive battery voltage (+6VDC), hereinafter referred to as VBAT. V_{DD} appears at the emitter of transistor 204. The collector of transistor 204 is coupled to its emitter by the parallel combination of two 200 Ω resistors. The cathode of a diode 208 is coupled to the emitter of transistor 204. The anode of diode 208 is coupled to ground. Diode 208 illustratively is a type 1N4148 diode.

The RESET terminal of μc 200 is coupled to the collector of a transistor 210 and through a 10K Ω resistor to V_{DD} . The emitter of transistor 210 is grounded. Its base is coupled through a 22K Ω resistor 212 to the junction of a .1 μF capacitor 214 and a 1M Ω resistor 216. The other terminal of capacitor 214 is coupled to VBAT. The other terminal of resistor 216 is coupled to ground.

An electronic log book mode (ELB) connector 220 has three terminals. A first of these, 222, is coupled through a 10K Ω resistor to terminals P 3.0/LCDCL and P 0.0/INT4 of μc 200. Terminal 222 is also coupled to ground through the parallel combination of a 680pF

-12-

capacitor and a 220K Ω resistor. Terminal 224 is coupled through a 10K Ω resistor to terminal P3.2 of μ c 200, and to ground through the parallel combination of a 680pF capacitor and a 220K Ω resistor. Terminal 226 is coupled
5 to ground.

The eight terminals 231-238 of the key housing portion 18 are coupled, respectively, to: μ c 200's terminal P7.3/KR7; μ c 200's terminal P7.2/KR6; μ c 200's P7.0/KR4; μ c 200's terminal P6.3/KR3; ground; one
10 terminal of a 220K Ω resistor 240, the remaining terminal of which is coupled to terminal 234; nothing (blank); and terminal 236.

A number of variables exist which affect the reading of the reacted chemistry on a strip 106. For the
15 reading to be as free of errors as instrument 10 can make it, these variables must be accounted for to the extent possible by instrument 10 in the process of calculating the end point remission of the reacted chemistry. One of these variables is humidity, and it is taken into
20 consideration by a humidity sensor 242 of standard configuration coupled between ground and an input terminal P0.3/SI/SB1 of μ c 200. Humidity sensor 242 is also coupled through a 1M Ω resistor 244 and a .01 μ F capacitor 246 to ground. VBAT is supplied to the emitter
25 of a PNP transistor 248, illustratively a BC858C. The collector of transistor 248 is coupled to key housing portion 18's connectors 236 and 238 and to the junction of resistor 244 and capacitor 246.

An internal EEPROM 250 has its CS, SK, DI and
30 DO terminals coupled, respectively, to the P7.1/KR5, P7.2/KR6, P7.0/KR4 and P6.3/KR3 terminals of μ c 200. The V_{cc} and ORG terminals of internal EEPROM 250 are coupled to the collector of transistor 248. The GND terminal of internal EEPROM 250 is coupled to ground. Internal
35 EEPROM 250 illustratively is a Catalyst Semiconductor

-13-

type CAT93C46 integrated circuit, as is the integrated circuit in code ROM key 64.

A series string of an 8.2K Ω resistor 252, a 10K Ω resistor 254, a 10K Ω resistor 256, and a 10K Ω resistor 258 is coupled between terminal P6.1/KR2 of μ c200 and ground. The junction of resistors 252, 254 is coupled to terminals VLC0 and BIAS of μ c 200. The junction of resistors 254 and 256 is coupled to terminal VLC1 of μ c 200. The junction of resistors 256 and 258 is coupled to terminal VLC2 of μ c 200.

Transducer 80 is coupled across terminal P2.3/BUZ of μ c 200 and ground. A diode 260 is coupled across transducer 80 with its anode coupled to ground and its cathode coupled to terminal P2.3/BUZ. Another diode 262 has its anode coupled to terminal P2.3/BUZ and its cathode coupled to V_{DD} .

The COM0-COM2 and DS10-DS0 terminals, respectively, of μ c 200 are coupled to respective terminals of the same names, pins 1-14, of LCD 76.

An infrared strip 106 sensor channel 166 includes an LED 264 and a light sensitive transistor (LST) 266 separated by a partition in a common housing (not shown). The larger prism 176 is mounted on printed circuit board 22 so that its bottom surface rests directly on the top surface of the housing in which LED 264 and LST 266 are housed. LED 264 and LST 266 illustratively are a Toshiba type TLP908 integrated circuit. Light from LED 264 shines upward through the bottom of the larger prism 176 and is reflected out through the lens of prism 176 onto the strip 106. The reflected light returns through the lens and is reflected downward within the prism 176 and out the bottom thereof where it is received by LST 266. The resultant conductivity of LST 266 corresponds to a certain percentage remission of the light from LED 264. That

-14-

percentage remission establishes whether a strip 106 is present in strip carrier body 120 and, to an extent, whether that strip 106, if present, is properly oriented.

The way the strip 106 and strip 106 orientation are detected is as follows. Light returning in channel 166 to the base of LST 266 causes it to conduct. A current mirror including NPN transistors 268 and 270 in conventional current mirror configuration provides equal currents through the collectors of these two transistors in response to current flow in the emitter of LST 266. A .47 μ F capacitor 272 is coupled across the collector and emitter of transistor 270 and discharges at a rate determined by the amount of light falling on the base of LST 266 to which LST 266 is sensitive. This configuration subtracts from the initial voltage across capacitor 272 the integral of the light falling on the base of LST 266. Current is supplied to LED 264 for a predetermined, set period of time. The remission from strip 106 to the base of LST 266 determines how deeply discharged capacitor 272 becomes. Capacitor 272 is then charged from a constant current source for a period of time which is measured using the system clock, until capacitor 272 has recharged to some reference voltage. The length of the period that capacitor 272 takes to recharge to reference voltage is a period of time, a number of strokes of the system clock, and converts to a digital value the percentage remission of channel 166. This translates into the presence or absence of a strip 106 in the strip carrier body 120 and, to an extent, its orientation in strip carrier body 120. The instrument 10, once it has established that a strip 16 is present in the strip carrier body, next decides whether the strip 106 is properly oriented with its reagent pad in front of slot 190 and prism 174, or whether the strip 106 is backward or upside down. Of course, the strip

-15-

architecture must be such that different ranges of percentage remission readings are presented for these different strip 106 orientations, and this is so. See U.S.S.N. 07/661,788.

5 To accomplish these objectives, the anode of LED 264 is coupled to VBAT and its cathode is coupled to the collector of a transistor 276, which illustratively is a type BC848C NPN transistor. The emitter of transistor 276 is coupled through an 82 Ω feedback resistor to ground. The base of transistor 276 is provided with periodic LED 264 drive signals from terminal P5.1 of μ c 200. The base of transistor 276 is also coupled through two diode-connected temperature compensation transistors 280, 282 in series to ground.

10 Transistors 268, 270, 280, 282 illustratively are a type MC3346D quad transistor integrated circuit. The emitter of LST 266 is coupled to the collector and base of current mirror transistor 268, and to the base of current mirror transistor 270. The collector and base of transistor 268 and the base of transistor 270 are also coupled to terminal P5.0 of μ c 200. The emitters of transistors 268, 270 are grounded. The collector of transistor 270, in addition to being coupled to capacitor 272, is coupled to the inverting (-) input terminal of a difference amplifier 286, and to the collector of a PNP transistor 288 such as a type BC858C transistor. The output terminal of difference amplifier 286 is coupled to the P3.1/SYNC terminal of μ c 200. The emitter of transistor 288 is coupled to terminal P5.3 of μ c 200.

20 The base of transistor 288 is coupled to the output terminal of a difference amplifier 290.

The inverting (-) and non-inverting (+) input terminals of difference amplifier 290 are coupled through a 20K Ω resistor and a 150 Ω resistor, respectively, to the collector of LST 266. A 5.1K Ω resistor is coupled from

35

-16-

the base of transistor 276 to the collector of LST 266 as well. The collector of LST 266 is coupled to the + input terminal of a difference amplifier 294, the - input terminal of which is coupled through a 150K Ω resistor to terminal P6.0/KRO of μ c 200. The output terminal of difference amplifier 294 is coupled to terminal P3.3 of μ c 200. The - input terminal of difference amplifier 294 is also coupled through a .01 μ F capacitor to ground.

Turning now to the mechanism and electronics by which the remission of the reagent pad portion of strip 106 is read when a strip 106 is properly inserted into strip carrier body 120, LED 182 is the beginning of channel 164. The anode of LED 182 is coupled to VBAT and its cathode is coupled to the collector of an NPN transistor 298. Transistor 298 illustratively is a type BC848C transistor. The emitter of transistor 298 is coupled through a 120 Ω feedback resistor to ground. The base of transistor 298 is coupled to terminal P5.2 of μ c 200, and through a 20K Ω resistor to the + input terminal of difference amplifier 294. The remission of the reagent pad of a strip 106 is supplied to a photosensor 300, such as a Siemens type TFA1001W integrated photosensor. Photosensor 300 is mounted in closely spaced relation to the bottom of the smaller prism 174 so that remissions from the chemistry region of strip 106 that enter the lens surface of prism 174 are reflected down through it and exit from its bottom into photosensor 300.

Power for photosensor 300 is provided through a PNP transistor 302, which illustratively is a type BC858C transistor. The emitter of transistor 302 is coupled to VBAT. Its base is coupled through a 62K Ω resistor to terminal P4.2 of μ c 200. Its collector is coupled to ground through a 22 μ F tantalum capacitor 304. The voltage VD1 across capacitor 304 is coupled across

-17-

terminals + VS and - VS of photosensor 300. A .01 μ F capacitor is also coupled across terminals + VS and - VS. The VSTAB and FCOMP terminals of photosensor 300 are joined through a 1M Ω resistor. The VSTAB terminal is
5 also coupled to the + input terminal of a difference amplifier 308. The - input terminal of difference amplifier 308 is coupled to its output terminal, making it an inverting amplifier. The output terminal of difference amplifier 308 is also coupled to the + input
10 terminal of difference amplifier 294. Difference amplifiers 286, 290, 294 and 308 illustratively are a type LM324A quad difference amplifier integrated circuit.

Terminal P6.2/KR2 is coupled through a 220K Ω resistor to the anode of a diode 310 which illustratively
15 is a type IN4148. The cathode of diode 310 is coupled to the INHIBIT terminal of photosensor 300. The conductor extending between the cathode of diode 310 and the INHIBIT terminal of photosensor 300 is capacitively coupled through a 680 Ω resistor to ground and through a
20 360 Ω resistor to the + input terminal of difference amplifier 286. The + input terminal of difference amplifier 286 is coupled through a 200 Ω resistor to the + input terminal of difference amplifier 290. The OUTPUT terminal of photosensor 300 is coupled to the - input
25 terminal of difference amplifier 286.

One terminal of an ON/OFF switch 312 operated by ON/OFF button 32 is coupled to ground. The other terminal of ON/OFF switch 312 is coupled to the P1.1/INT1 terminal of μ c 200. The P1.2/INT2 terminal of μ c 200 is
30 coupled to one terminal 316 of a memory switch 314 operated by memory button 50. Terminal 316 of memory switch 314 is coupled through a 220K Ω resistor to ground. The other terminal of memory switch 314 is coupled through a 220K Ω resistor to the P1.1/INT1 terminal of
35 μ c 200.

-18-

The symbols which can appear on LCD 76 include numbers 00.0 through 99.9, the indications mg/dL (milligrams per deciliter), mmol/L (millimoles per liter), mem (which stands for memory), a battery icon, an icon of a blood droplet being deposited on a strip, the word code, and an error icon, a box with an "X" through it, each quadrant of the box being capable of being separately energized.

Referring now to Fig. 10, the instrument 10 is turned on by depressing ON/OFF button 32. Instrument 10 actuates prior to release of ON/OFF button 32. Immediately after the instrument 10 is turned on, it performs a power-on system integrity test and a battery voltage test. If the battery 86 voltage is below 4.5 volts, a battery low warning (battery icon on LCD 76) is displayed. If the battery 86 voltage is below 4.2 volts, the instrument 10 will not turn on. Following being turned on, all segments of the display 76, including all icons, are displayed for 2 seconds. If it is enabled, the transducer 80 sounds for the first one-half second of this 2 second display check.

After 2 seconds, all segments and icons disappear and the ROM code number from key 64 and code icon appear on LCD 76 for 2 seconds, then disappear. During this time, the instrument 10 scales itself using the remission of white tile 142. Scaling is followed by the lighting of the strip icon, right arrow icon, and flashing blood drop icon. This icon display prompts the user to apply blood to the strip 106 and then to insert the dosed strip 106 into the opening 104 provided therefor in instrument 10.

The user applies blood to the strip 106 and allows it to soak into the strip mesh until it is fully absorbed. Within two seconds of proper insertion of the strip 106, the instrument 10 deletes the strip icon,

-19-

blood drop icon and right arrow icon from display 76, and begins the timing period for the chemistry in the reagent pad of strip 106 to react with the medically significant component, glucose in this example, of the applied blood.

5 Within two seconds of insertion of the strip 106, the display 76 sequentially displays (in clockwise rotation) the quadrants on the error or "X" display at a rate of one segment per half second. No timing need be displayed on the instrument 10's LCD 76 because of the employment

10 of an endpoint chemistry on strips 106. When the strip 106's reaction is determined by the instrument 10 to have reached an endpoint, the instrument 10 beeps once and then displays a blood glucose value and the mg/dL icon. The instrument 10 also displays the strip icon and left

15 arrow icon to prompt the user to remove the reacted strip 106. The glucose result is stored in the newest (first) memory location, pushing all previously stored glucose readings down one location in memory.

After the strip 106 is removed, the instrument

20 10 again rescales itself from the white tile 142 to ready itself for the next strip 106 reading. The instrument 10 then returns to the dosed strip insertion prompt.

The instrument 10 can verify that an unreacted strip 106 is acceptable for use. It does this by reading

25 the unreacted strip 106 to make sure that its reagent pad remission value is within the specified percent remission limits stored in the code ROM key 64. Performance of this check is at the user's discretion. The instrument 10 is capable of performing this check when the

30 instrument is prompting for a dosed strip or during a memory recall display.

To perform this strip 106 integrity check, the user removes an unreacted strip 106 from the vial containing such strips and inserts the unreacted strip

35 106 into the instrument 10's slot 104 with the reagent

-20-

pad facing the optics. Within two seconds after a strip 106 has been inserted, the instrument 10 detects the presence of a strip 106 and begin its timing display. During this display, the user must depress the memory button 50 once. This causes the instrument 10 to perform the strip 106 integrity check. After the memory button 50 has been pressed, the instrument 10 will read the strip 106's remission and compare the strip 106's remission against the programmed limits that have been provided by the lot specific ROM key 64.

Strip 106 integrity approval is signaled through the strip removal prompt and a single beep. Strip 106 approval permits the user to proceed with a test on a reacted strip 106 by prompting for a dosed strip after the unreacted strip 106 is removed.

Strip integrity errors are signaled through the display of the flashing error ("X") icon, flashing strip icon and three beeps. The instrument 10 remains in this display state until the bad strip 106 is removed. After strip 106's removal, the instrument 10 prompts for a dosed strip.

Glucose test values are stored automatically after every test using "first (oldest) in, first deleted" and "last (newest) in, first recalled" protocols. Once the memory has filled to its thirty reading capacity, each new reading added causes the oldest reading to be deleted from memory.

Memory recall mode is accessible from the dosed strip prompt. Memory recall function is initiated by pushing the memory button 50 once. This displays the first memory location (1).

After one second, the display changes to display the contents (a glucose reading) of the selected memory location. The display reverts to the memory location display (1 in this example) after 4 seconds. If

-21-

no button is pushed, the cycle of memory location and memory location contents continues to repeat itself for 5 minutes before the instrument 10 turns itself off. The memory display cycle can also be terminated by the
5 insertion of a test strip 106 into the instrument 10. Recall of the remaining values from memory is accomplished by pressing the memory button 50 over and over again until all thirty stored values and their memory locations have been displayed. Each time the
10 memory button 50 is depressed, the next memory location is displayed. Memory locations and results cycle to location 1 once the user advances beyond the oldest value. If fewer than 30 results are stored in memory, the first location (location 1) is displayed following
15 the last result stored when the memory is advanced beyond the last result. The memory icon is displayed at all times during memory recall.

If at any point a strip 106 is inserted, the instrument 10 reverts to the test/timing mode. Insertion
20 of a strip 106 (reacted or unreacted) automatically causes the instrument 10 to revert to this mode and resets memory to the first (newest) location.

The instrument 10 uses the code ROM key 64 as follows: With the instrument 10 off, the user removes
25 the old ROM key 64 from the instrument 10 and discards it. A new ROM key 64 is packaged in every supply of strips 106. The user inserts the new ROM key 64 containing information pertinent to the new supply of strips 106 into the key housing portion 18 on the
30 instrument 10 prior to turning the instrument 10 on. When the instrument 10 is turned on, the instrument 10 checks the integrity of the data contained in ROM key 64 via a checksum method. If the ROM key 64 data is found to be questionable, then a code error is displayed. During the
35 performance of a test, prior to the calculation of a new

-22-

glucose result, the instrument 10 checks the ROM key 64 to see if it has been changed. If the ROM key 64 has been changed since the instrument 10 was turned on, a code error is displayed. The instrument 10 remains in
5 this display until it either times itself off (5 minutes), or is turned off.

When test results exceed the upper limit contained in the ROM key 64, then the message HI is displayed in place of a numeric result. If the result
10 does not exceed the lower limit contained in the ROM key 64, LO appears on the display. The mg/dL icon is displayed in both cases.

Instrument 10 verifies the remission of its white tile 142 and signifies a dirty tile 142 by
15 displaying CLE (for "clean") on display 76. The instrument 10 does not permit the user to begin a testing procedure or memory recall from this display. The only remedy for this error is to turn the instrument 10 off. This error occurs if the slope calculated from the
20 remission of the white tile 142 is not within instrument 10's internal slope limits, typically +5% to -10% of its target value. This error also occurs if the instrument 10 is turned on with a strip 106 inserted in it.

The instrument 10 shuts itself off
25 automatically 5 minutes after the last button push or strip 106 insertion. Automatic shut off occurs regardless of instrument 10 mode or the last button pressed. Depressing ON/OFF button 32 while the instrument 10 is on turns the instrument 10 off.

30 Transducer 80 provides an audible beep: when the instrument 10 is turned on (0.5 second); when a strip 106 is inserted into opening 104 (0.25 second); whenever an error message is displayed (three times for 0.1 second each); at the end of a test to indicate that a result is
35 displayed or an unreacted strip 106 is usable (0.25

-23-

second); and, whenever either button 32 or button 50 is depressed as a "key click" sound (two cycle duration). Transducer 80 actuation can be enabled/disabled by the simultaneous actuation of both ON/OFF button 32 and
5 memory button 50 as the instrument 10 is turned on.

The instrument 10 denotes errors by displaying the "X" icon in combination with an error message or other icon. There are two error types: recoverable and non-recoverable. Strip errors are correctable by removal
10 of the strip 106 from the instrument 10. All other errors are non-recoverable and require the instrument 10 to be turned off in order to clear the error.

The following errors are recoverable strip errors. Removal of the strip will cause the instrument
15 10 to return to the dosed strip prompt: the Bad Strip error, caused by an improperly reacted strip 106 or a strip 106 which is degraded in any way as to make its state indeterminable; and the Strip in Backwards error, caused by the strip 106 being inserted with its blood
20 application side toward the instrument 10's optics.

The following errors are non-recoverable, as they are the results of instrument measurement problems: the Dirty Optics error, which occurs if the instrument
25 10's white tile 142 is dirty or degraded, or if the instrument 10 is turned on with a strip 106 already inserted in it; the Electronics Fault error, which is caused by the detection of a fault during the instrument 10's power-on self-test or during a diagnostic check; the
30 Strip Removed During Test error, which is caused by removing a strip 106 during the performance of a test so that instrument 10 is unable to complete the test cycle; and, the Coding error, which is caused by the detection of a code ROM key 64 read error or a mismatch of the lot code number read when instrument 10 is turned on with the
35 lot code number read just prior to the calculation of a

-24-

glucose result. The only remedy for these errors is to turn the instrument 10 off.

The instrument 10 provides certain prompt messages to the user, including: the Strip Removal prompt, by which the instrument prompts the user to
5 remove a strip 106 by displaying the strip icon and left arrow (<) icon; and the Dosed Strip prompt, by which the instrument 10 prompts the user to insert a dosed strip 106 by displaying the strip icon, right arrow (>) icon,
10 and flashing the blood drop icon. Flashing segments or icons in any mode of operation are displayed for 0.5 second and off for 0.5 second.

In addition to its normal operating mode for determining the remissions of reacted test strips, the
15 instrument 10 has a diagnostic software package that is accessed via installation of a special diagnostic ROM code key 64. The diagnostic ROM code key 64 is installed in key housing portion 18 before the instrument 10 is
20 turned on. Once the instrument 10 is turned on with the diagnostic ROM code key installed, the following functions are accessible instead of the normal operating modes.

Once instrument 10 is turned on in the diagnostic mode, instrument 10 enters the check strip
25 diagnostic. The instrument displays d1 in the glucose value field, or results field, for one second. After one second the instrument 10 additionally displays the strip icon and right arrow icon to prompt the operator to insert a check strip 106 provided with the diagnostic
30 code ROM key 64. If the user presses memory button 50 during this display, the instrument 10 advances to the next diagnostic test.

Upon insertion of the check strip, the instrument 10 measures the remission of the check strip
35 and compares this remission to a target remission value

-25-

range stored in the diagnostic code ROM key 64. If the measured remission agrees with the target value range then the results field of the display 76 is blank, transducer 80 beeps once and the user is then prompted to
5 remove the check strip by turning off the right arrow icon, and turning on the left arrow icon while continuing to display the strip icon.

Upon removal of the check strip from the instrument 10 after a successful check, the instrument 10
10 returns to the start of the check strip diagnostic routine and remains in this routine until the instrument 10 is turned off, or until the user advances to the next diagnostic routine by pressing the memory button 50.

If the measured remission of the check strip
15 does not match the target value in the diagnostic code ROM key 64, the instrument 10 beeps three times, CLE flashes in the results field on display 76, and the error icon "X" is displayed. The only way to exit this display is to turn instrument 10 off.

20 If the user advances past the first diagnostic check by pressing memory button 50, then the IR (infrared) sensor check is prompted by displaying d2 in the results field. After one second, the instrument 10 checks for the presence of a strip in the instrument by
25 using the reagent pad detector. If the instrument 10 determines that a strip 106 is in the instrument 10, it prompts the user to remove the strip by displaying the strip icon and left arrow icon until the strip is removed.

30 If the instrument 10 detects no strip, the instrument 10 then reads the IR detector 266. If the IR detector 266 reads a remission value inconsistent with an empty strip carrier 120, 134, then instrument 10 displays
35 OFF in the results field of display 76 to signify that the IR detector 266 is sensing a strip 106 when none is

-26-

present. This display will remain until the instrument 10 is turned off.

If the instrument 10 determines that no strip 106 is present and that the IR detector 266 sees no strip 106, then it prompts the user to insert a strip 106 by displaying the strip icon and right arrow icon until a strip 106 is detected by the reagent pad detector 300. Once a strip 106 is sensed by the reagent pad detector 300, the strip detector 266 is measured. If this measurement is inconsistent with the presence of a strip 106 in the instrument 10, then the instrument 10 beeps three times, the display field displays OFF and the error X icon flashing until instrument 10 is turned off.

If the IR detector 266 senses the presence of a strip 106 in the instrument 10, then the results field of display 76 is blank, and the user is prompted to remove the strip 106 by displaying of the strip icon and left arrow icon. Once the strip 106 is removed, the display 76 returns to the d2 display until the user advances to the next diagnostic check by pressing memory button 50 or until instrument 10 is turned off.

If the user advances past the customer control strip diagnostic and past the IR sensor 266 check by using memory button 50, then the display check will be prompted by displaying d3 in the results field for one second. After one second, all segments of the display 76 will be displayed for five seconds. Display 76 then alternates between the d3 display and the all segments display until the user advances to the next diagnostic check by pressing memory button 50 or until instrument 10 is turned off.

If the user advances past the first three diagnostic checks by using memory button 50, then the d4 prompt for the transducer 80 check will be displayed in the results field. After one second, transducer 80 beeps

-27-

for two seconds regardless of whether the user has transducer 80 switched off or not. After transducer 80 has beeped for two seconds, it will turn off for one second and then on for two seconds and so on, until the user advances to the next diagnostic check by pressing memory button 50 or until the instrument 10 is turned off.

If the user advances past the first four diagnostic checks using memory button 50, then instrument 10 enters the battery check and prompts the user by displaying d5 in the results field, and displaying the battery icon. At the end of one second, the instrument 10 repeats its power-on battery check.

The instrument 10 displays a number based on the following calculation:

$$\frac{\text{present battery voltage}}{\text{battery low warning voltage}} \times 100$$

Of course, numbers of less than 100 are displayed if the battery icon was being displayed prior to entering the d5 diagnostic.

This display will remain on until the user returns to the first diagnostic check, d1, by pressing memory button 50 or until instrument 10 is turned off.

The operation of certain software functions of the disclosed instrument may be better understood by reference to the attached source listing for μC 200 and illustrative data stored in the EEPROM of a typical key 64. In the source listing, CRD or Chemistry Remission Difference is the amount of remission difference which a delta must be less than in order to reach the end of reaction (EOR). CRD is a 12 bit number in bank 1 RAM which is an input to the function REACTION. The format of CRD is a 12 bit binary remission multiplied by forty.

IWMI is an 8 bit number in bank 1 RAM which is an input to function REACTION which determines the number of half second increments of time to delay before taking

-28-

the first remission. IWMI is allowed to be from 0 to 255. If IWMI equals 0, then no delay will occur. If it equals 1 then one half second of delay will occur, and so on.

5 TINC is an 8 bit number in bank 1 RAM. TINC is an input to the function REACTION which determines the number of half second increments of time which will elapse between successive remission readings. TINC is permitted to be from 0 to 255. If it is 0, then one
10 half-second increment of time will elapse. If it is 1, then two half-second increments will elapse, and so on.

NPS is an input to the function REACTION which is a 4 bit number in bank 1 RAM. NPS represents the number of remission readings that will be taken between
15 comparisons. It is allowed to be from 1 to 6. If NPS=1, then one remission reading is taken between those which are compared, and so on.

NPSA is an 8 bit number in bank 1 RAM which is an input to function REACTION. NPSA is a function of
20 NPS. NPSA essentially contains the same information as NPS but in a form which is more easily used by the processor. It is defined as:

$$\text{NPSA} = (\text{NPS} + 1) * 8$$

IWMA is an 8 bit bank 1 RAM number. IWMA is an
25 input to function REACTION. IWMA controls the number of comparisons that the EOR portion of the algorithm will make before it terminates. IWMA is permitted to be from 1 to 255. If IWMA equals 1, then only one comparison will be made. If IWMA equals 2, then a maximum of two
30 will be made, and so on.

ERS is a 1 bit number in bank 1 RAM which is an input to function REACTION. ERS causes the MAX_F flag to be set if the function REACTION reaches EOR by reaching
IWMA.

35 EORREM 1 is a 32 bit floating point number in

-29-

bank 1 RAM which contains the last remission taken by function REACTION. EORREM 1 is an output of function REACTION.

EORCOUNT is an 8 bit bank 1 RAM number which contains the number of comparisons done during EOR. It will never equal 0. It will always be from 1 to 255. EORCOUNT is an output of function REACTION.

MAX_F is an output of function REACTION. MAX_F is a 1 bit bank 1 RAM number. MAX_F is set equal to 1 if EOR is reached by the number of comparisons equalling IWMA and ERS is also 1. If these conditions are not met, then MAX_F is cleared to zero.

TRACE_F is a 1 bit bank 0 (zero) RAM input to module REACTION which indicates that the meter is in TRACE MODE. In TRACE MODE, all remission readings are sent out the I/O port.

SE_F is a 1 bit bank 1 RAM number which is an output. If SE_F is set, a strip error has occurred. Two conditions can cause this: (1) EORREM 1 less than COL or greater than COH; or (2) EOR reached by finding a delta less than CRD, but the last 2 remissions taken did not have deltas less than CRD.

COL is a bank 1 RAM location. Its format is a 12 bit binary remission multiplied by 40. All EORREM 1 values found by this function are compared to this number. If EORREM 1 is less than COL, then SE_F is set.

COH is a bank 1 RAM location. The format is a 12 bit binary remission times 40. All EORREM 1 values found by this function are compared to this number. If EORREM 1 is greater than COH, then SE_F is set.

REACTION ASSESSMENT

Summary

Reaction Assessment is responsible for

-30-

observing the strip adaptor and determining when the remission of the object in the strip adapter has reached the EOR. It does this by periodically taking full power chemistry pad remissions and analyzing these against parameters found in the external ROM. The final
5 remission is placed in a reserved location in RAM. In addition, Reaction Assessment determines how many comparisons were made during the search for EOR. During the operation of this module, a rotating arrowhead is
10 displayed on the LCD display as a means of indicating that this module is operating. This module also transmits the value of each remission taken out the serial port if TRACE_F is set. If the MEM button is pushed during the execution of this module, then control
15 passes to the STRIP INTEGRITY module and Reaction Assessment is aborted.

More Detailed Explanation

This function is responsible for observing the strip adapter and determining when EOR occurs or if the
20 MEM button is pushed. In addition, Reaction Assessment displays a rotating arrow on the LCD as a means of providing a visual indication that the meter is busy. It also outputs each remission taken if TRACE_F is set.

25 Reaction Assessment begins by clearing the LCD and darkening a single arrowhead. The first arrowhead darkened is not specified and will vary indeterminately. For the duration of the execution of this function the LCD will change its display every half second. The
30 display will change by lightening the arrowhead that is currently dark and darkening the arrowhead which is adjacent to it in the clockwise direction. At the completion of this function the duration of time since the LCD display was changed will be between approximately
35 20 and 300 msec. A typical time will be around 100 msec.

-31-

This duration varies with the time required to take a remission and whether

TRACE_F is set or not. It is intended that if a continuation of the rotating arrowhead display is desired following the completion of this function, then it is
5 necessary to wait another half second before changing the LCD display. In addition, SE_F is cleared at this time.

Reaction Assessment employs the power conservation module so that when it is not actively
10 taking remission readings or doing calculations it puts the meter in a power conservation mode which minimizes power consumption yet still permits the meter to respond immediately to any event which can cause a termination of power savings.

15 The second thing that this function does is to examine RAM location IWMI to determine the amount of initial delay before taking the first remission reading. IWMI is an 8 bit binary integer. Each count of IWMI represents a half second of delay. IWMI may be from 0 to
20 255. 0 implies no delay and 255 implies 255 half seconds of delay. An example of IWMI is illustrated in Fig. 11. Here, IWMI has a value of 3. This causes 1.5 seconds of delay from the start of this function to where the first remission is taken.

25 Once the requirements of IWMI have been met, then a single, full power remission is taken on the chemistry channel. This remission is referred to as the first remission reading.

The next task that the function REACTION
30 performs is a TRACE CHECK. This involves checking the 1 bit RAM location TRACE_F. If this location holds a 0, nothing happens. If it holds a 1, then the remission just taken is sent out the serial port as a 4 byte floating point number (least significant byte first) in
35 the PC communication format.

-32-

The EOR portion of this function is conducted at this time. To reach EOR, one of two events must occur. Either a comparison of two remissions is found to have a change, or delta, which is less than CRD, or a time-out occurs after a number of comparisons equal to IWMA has been made.

End of Reaction by achieving a DELTA < CRD

CRD is a number found in RAM which is a limit for how small delta must be in order to constitute EOR. Delta is the result of subtracting the most recent remission from a prior remission determined by ROM code key 64 parameter NPS. The comparison between CRD and a delta is made as follows:

Is $|\text{delta}| < |\text{CRD}|$?

If the answer to this question is yes, then EOR has been reached. If not, then another comparison must be made.

The timing for these events can best be described in connection with Fig. 11. The first remission reading has already been taken (time = 1.5 sec.). The amount of delay until a subsequent remission reading is taken is controlled by TINC. If TINC equals 0, then the delay increment will be one half second. If TINC equals 1, then 2 increments of one half second will occur. TINC is permitted to vary from 0 to 255, so it will provide delays of from .5 to 128 seconds. The example in Fig. 11 shows a TINC of 1 which causes a delay of two one half second increments between remission readings.

A delta is formed by comparing two remission readings. The two remissions compared are determined by RAM locations NPS and NPSA. $\text{NPSA} = (\text{NPS} + 1) * 8$. NPS refers to how many previous remissions will be skipped before using a remission to form a delta. If NPS equals

-33-

1, as in the example of Fig. 11, then one remission is skipped. For this example, the first delta is calculated after the third remission reading is taken. The delta is calculated by subtracting the first remission reading
5 from the third remission reading. NPS is permitted to be from 0 to 6, permitting from 0 to 6 remission reading to be skipped between comparisons. If, for example, NPS=6, six remission readings are skipped, and the remission reading which was detected seven remission readings ago
10 is the one that is used to calculate delta.

RAM location EORCOUNT is used to keep track of how many comparisons are made during this function. At the beginning of this function, EORCOUNT is set equal to zero. RAM location EORCOUNT is incremented by 1 each
15 time a comparison is made until a delta less than CRD is found. If a delta is found that is less than CRD, then the software decides that EOR has been reached. In the example provided in Fig. 11, a delta less than CRD was reached when the fourth reading was taken. Therefore,
20 the final EORCOUNT value for this example is 2.

Once the EOR is reached by finding a delta less than CRD, one more remission reading is taken after a time interval controlled by TINC. Following this remission, a Trace Check remission is read. This Trace
25 Check remission is also compared to a previous remission controlled by NPSA. EORCOUNT is not incremented when this remission is read and its corresponding delta is calculated. If this delta is less than CRD, then the remission just taken will be stored at RAM location
30 EORREM1. The software will then continue as described following the next paragraph. If this delta is not less than CRD, then the meter will continue as described in the next paragraph. Fig. 11 does not illustrate this condition since the fifth reading is quite low and the
35 delta (THIRD DELTA) created thereby is greater than CRD.

-34-

However, if THIRD DELTA had been less than CRD, then the fifth reading would have been the last and would illustrate this condition.

The meter next takes another remission reading immediately without waiting for TINC. This remission is compared to the same remission as is the remission taken after delta less than CRD. The example in Fig. 11 shows a delta being created between the third reading and the sixth reading. If the delta is not less than CRD, then the 1 bit RAM location SE_F is set. EORCOUNT is not incremented when this remission is read and its corresponding delta is calculated. This remission is stored at RAM location EORREM1. A Trace Check is performed. The function now proceeds as described below.

Each time a comparison is made, the RAM location EORCOUNT is incremented by 1. EORCOUNT is zeroed at the beginning of this function. If so many comparisons are made that EORCOUNT equals IWMA, then EOR will have been reached. If this happens, and if the 4 bit RAM location ERS equals 1, then the 1 bit RAM location MAX_F is set. Otherwise MAX_F is cleared by this function, regardless of how this function terminates. An example of this type of EOR is given in Fig. 12. Here, IWMA equals 5. After five comparisons (deltas) are calculated and none of these deltas are found to be less than CRD, EOR is reached.

Once EOR has been found by reaching IWMA, then another remission is taken after TINC has elapsed. Following this remission, a Trace Check remission is read immediately. This remission is then written into RAM location EORREM1.

Regardless of how EOR was reached, this function now proceeds by outputting 4 bytes of EEH if the TRACE_F is set. This indicates to a PC that the function REACTION is completed.

-35-

The last thing REACTION does is to check if the EORREM1 value is greater than RAM number COL and less than RAM number COH. If EORREM1 is not between COL and COH then the SE_F bit in RAM is set. If EORREM1 is
5 between COL and COH then the SE_F bit is not modified. It is possible that EOR was reached by finding a delta less than CRD, and that the last two remissions did not meet the CRD requirements but the last remission was within the limits set by COL and COH. In this case, a strip
10 error is still considered to have occurred, and the SE_F bit remains set.

Throughout this entire function, the meter is alert for a pressing of the MEM button. If the MEM button is pressed, then a branch to the STRIP INTEGRITY
15 function is performed. This terminates the Reaction Assessment function.

As previously discussed, the meter 10 has a dual-mode input/output (I/O) port which is accessed via the ELB connector 220. In normal operation, the results
20 displayed by the meter 10 at the end of a test sequence are transmitted, at the end of the test sequence, in a non-standard serial format on connector terminal 224.

During factory calibration and testing, the I/O port 220 is used for input and output of electronic
25 calibration information and measurements made by the meter 10 to establish the relationships between the meter 10's electronic measurements and its remission scale. Calibration data are serially received by the meter 10 on connector terminal 222 in a non-standard format and
30 stored in the meter 10's internal EEROM 250.

During the calibration process, control strips 106 of known remission are presented to the meter 10's optics and electronic readings are taken for each strip 106 presented. An external computer requests from the
35 meter 10, via the I/O port 220, the electronic

-36-

measurements corresponding to each strip 106. A program in the external computer, knowing the meter 10's electronic readings for each strip 106 and the respective remission for each strip 106, calculates calibration factors for the meter 10 which are serially transmitted to the meter 10 and stored by the meter 10 in its internal EEROM 250.

These calibration factors are used by the meter 10, during its scaling operation, to re-establish the remission scale from the meter 10's white standard tile 142. They are also used by the meter 10 to check the validity of the remission scale relative to its initial value established during factory calibration. Failure of the meter 10 to reproduce the factory calibration scale to within limits held in the calibration factors results in a CLE error being displayed on LCD 76.

Calibration factors are stored along with the 30 glucose results in the nonvolatile EEROM 250. Separate checksums for the calibration factors and glucose memory allow for integrity checks on both groups of data independently, allowing the glucose memory to be updated at the end of each test sequence without disturbing the integrity of the calibration factors. The calibration factors checksum can be read, but not written to, by the meter 10. When the meter 10 is first turned on, new checksums are calculated by the meter 10 for both the calibration factors memory and the glucose memory contained in the EEROM 250. Failure of these newly-calculated checksums to match identically with the checksum values stored in the EEROM 250 for the calibration factors and glucose memory results in an OFF error being displayed on LCD 76.

The meter 10 can operate in a non-ELB mode through connector 200. The signals are inverted with logic one equalling zero volts and logic zero equalling

-37-

VBAT. The data transmission format is similar to RS232 standard with serial data format, a start bit, eight data bits (least significant data bit first) and a stop bit in each byte. The baud rate is 4800. The RS232 standard

5 voltage level is shifted to be compatible with the voltages of the meter 10, and, of course, the meter 10's output voltage level must be shifted to the RS232 standard. The protocol for communicating with the meter 10 when it is turned off is to send an attention

10 character followed by a 50msec delay followed by another attention character. When the meter 10 is on, the protocol to begin communication with the meter is to send a single attention character. The attention character is the binary equivalent of decimal 43 (00101011). Once the

15 meter 10 has received the attention character, it expects to receive an address character, from decimal 0 to decimal 255, exclusive of decimal 43. Multiple meters 10 can be coupled to the same line. Address 0 will begin communication with all of them. All other addresses will

20 communicate with only that meter 10 whose address is sent. Each command or request to the meter 10 is identified by an even number between decimal 4 and decimal 254 inclusive. The commands are the odd multiples of 2. The requests are the even multiples of

25 2. To avoid unintentional or unauthorized erasure of information, the instrument 10 is always locked unless a key request has been received by it. A command immediately following a key request will be processed by the instrument 10. However, processing of either a

30 command or a request by the instrument 10 will scramble the key data, so a key request must be sent before each command can be processed. After a command is received, the instrument 10 sends an acknowledge character (06 hexadecimal) to signal that the instrument 10 is ready to

35 receive data.

-38-

When a command or a request is completed, the meter is ready to receive the next command sequence. It will remain in this state until it receives request digital 152, turn off. This shuts the meter 10 off, returning it to normal operation.

The following is a list of valid commands and requests and explanations. All values are 8 bit binary. Spaces and punctuation are for appearance only and are not contained. Each small letter "n" in parentheses indicates a byte of data that must be sent as part of the command or request by or to the communicating computer.

SEND KEY - ATN, ADR, 4 (nnnnnn) - Key to unlock the device "NWTCHM" - 48 bits of key code. Places the 48 bits of key code in the key data area and returns to the home state.

READ LEDTIME 1 - ATN, ADR, 8 - Read the chemistry pad LED on time (channel 1). A single byte is returned. The time in microseconds is found by the following formula:

Time = (n*87+1100)/1000 microseconds
Sends "n" over the serial port as one byte number.

WRITE LEDTIME 1 - ATN, ADR, 10(n) - Write the chemistry pad LED on time. n = the number used by the A/D routine. The LED on time in microseconds is found by the following formula:

Time = (n*87+1000)/1000 microseconds.
Writes n to RAM and to internal EEPROM.

READ CHANNEL 1 WHITE TILE REMISSION - ATN, ADR, 12 - Read the white standard remission value, which is used to calculate the remission of the chemistry pad. Sends the target white value over the serial port as a four byte floating point number, least significant bit (LSB) first.

WRITE CHANNEL 1 WHITE TILE REMISSION - ATN, ADR, 14(nnnn) - Write the white standard remission value,

-39-

which is used to calculate the remission of the chemistry pad. Writes the four byte floating point number received over the serial port to RAM and to EEPROM. LSB is sent first.

- 5 **READ CHANNEL 1 SLOPE - ATN, ADR, 16 -** Read the slope used to calculate the remission of the chemistry pad. Sends the slope value over the serial port as a four byte floating point number, LSB first.
- WRITE CHANNEL 1 SLOPE - ATN, ADR, 18(nnnn) -**
- 10 Write the slope used to calculate the remission of the chemistry pad. Writes to RAM the slope value which is used in the remission routine. This value is sent as a floating point number, LSB first.
- READ CHANNEL 1 "Y" INTERCEPT - ATN, ADR, 20**
- 15 (nnnn) - Read the y (remission) intercept value which is used to calculate the chemistry pad remission. Sends the stop value over the serial port as a four byte floating point number, LSB first.
- WRITE CHANNEL 1 "Y" INTERCEPT - ATN, ADR**
- 20 22(nnnn) - Write the y (remission) intercept value which is used to calculate the chemistry pad remission. Writes the slope value which is used in the remission routine to RAM. This value is sent as a floating point number, LSB first.
- 25 **CHANNEL 1 MAKE SLOPE - ATN, ADR, 24 -** Use the latest A/D conversions and create a new chemistry pad slope. Take the last A/D (LED on and LED off) readings and create a slope which can be used to calculate chemistry pad remissions. (This assumes the chemistry
- 30 pad remission equals the white standard remission.)
- READ CHANNEL 1 TARGET SLOPE - ATN, ADR, 28 -**
- Read target slope. The initial calibration slope (for the chemistry pad) as determined by the black strip-white strip calibration procedure is sent over the serial port
- 35 as a four byte floating point number, LSB first.

-40-

WRITE CHANNEL 1 TARGET SLOPE - ATN, ADR, 30(nnnn) - Write target slope. Load the initial calibration slope (for the chemistry pad) as determined by the black strip-white strip procedure to RAM and
 5 **EEPROM**. It is sent as a four byte floating point number, LSB first.

READ CHANNEL 1 REMISSION - ATN, ADR, 32 - Read the most recently acquired remission value of the chemistry pad. Sends the most recently acquired
 10 remission value over the serial port as a four byte floating point number, LSB first.

WRITE CHANNEL 1 REMISSION - ATN, ADR, 34(nnnn) - Write the remission value of the chemistry pad to RAM. It is sent as a floating point number, LSB first.

CALCULATE CHANNEL 1 REMISSION - ATN, ADR, 36(nnnn) - Calculate a chemistry pad remission. Takes the chemistry slope, y-intercept, and the last A/D conversions (LED on and LED off) and uses them to calculate the chemistry pad remission.

READ LEDTIME 2 - ATN, ADR, 40 - Read the IR channel LED on time. A single byte is returned. The time in microseconds is found by the following formula:

$$\text{Time} = (n*87+1100)/1000 \text{ microseconds.}$$

Sends n over the serial port as a one byte number.

WRITE LEDTIME 2 - ATN, ADR, 42(n) - Write the IR channel LED on time. n = the number used by the A/D routine. The LED on time in microseconds is found by the following formula:

$$\text{Time} = (n*87+1100)/1000 \text{ microseconds.}$$

Writes n to RAM and to internal EEPROM.

READ CHANNEL 2 WHITE TILE - ATN, ADR, 44 - Read the white standard remission value, which is used to calculate the remission of the IR channel (external calibration strip). Sends the master grey value over the
 35 serial port as a four byte floating point number, LSB

-41-

first.

WRITE CHANNEL 2 WHITE TILE - ATN, ADR, 46(nnnn)

- Write the white standard remission value, which is used to calculate the remission of the IR channel. Writes the
5 four byte floating point number received over the serial port to RAM and to EEPROM. LSB is sent first.

READ CHANNEL 2 SLOPE - ATN, ADR, 48 - Read the

slope used to calculate the remission of the IR channel. Sends the slope value over the serial port as a four byte
10 floating point number, LSB first.

WRITE CHANNEL 2 SLOPE - ATN, ADR, 50 - Write

the slope used to calculate the remission of the IR channel. Writes the slope value which is used in the remission routine to RAM. The value is sent as a
15 floating point number, LSB first.

READ CHANNEL 2 "Y" INTERCEPT - ATN, ADR, 52 -

Read the y (remission) intercept value which is used to calculate the IR channel remission. Sends the slope value over the serial port as a four byte floating point
20 number, LSB first.

WRITE CHANNEL 2 "Y" INTERCEPT - ATN, ADR, 54

(nnnn) - Write the y (remission) intercept value which is used to calculate the IR channel remission. Writes the slope value which is used in the remission routine to
25 RAM. This value is sent as a floating point number, LSB first.

CHANNEL 2 MAKE SLOPE - ATN, ADR, 56 - Use the

last A/D conversions and create a new IR channel slope. Take the last A/D (LED on and LED off) readings and
30 create a slope which can be used to calculate IR channel remissions. (This assumes the IR channel remission equals the white standard remission).

READ CHANNEL 2 TARGET SLOPE - ATN, ADR, 60 -

Read target slope. The initial calibration slope (for
35 the IR channel) as determined by the black strip-white

-42-

strip calibration procedure is sent over the serial port as a four byte floating point number, LSB first.

5 **WRITE CHANNEL 2 TARGET SLOPE - ATN, ADR, 62**
 (nnnn) - Write master slope. Load the initial calibration slope (for the IR channel) as determined by the black strip-white strip procedure to RAM and EEPROM. It is sent as a four byte floating point number, LSB first.

10 **READ CHANNEL 2 REMISSION - ATN, ADR, 64 - Read**
 the remission value of the IR channel. Sends the most recently acquired remission value over the serial port as a four byte floating point number, LSB first.

15 **WRITE CHANNEL 2 REMISSION - ATN, ADR, 66 (nnnn)**
 - Write the remission value of the blood sensor pad to RAM. It is sent as a floating point number, LSB first.

20 **CALCULATE CHANNEL 2 REMISSION - ATN, ADR, 68 -**
 Calculate a blood sensor pad remission. Takes the chemistry slope, y-intercept, and the last A/D conversions (LED on and LED off) and calculates the blood sensor pad remission.

DO CHANNEL 1 LED "ON" ADC - ATN, ADR, 76 - A/D
 convert the chemistry pad with the LED on.

DO CHANNEL 1 LED "OFF" ADC - ATN, ADR, 78 - A/D
 convert the chemistry pad with the LED off.

25 **DO CHANNEL 2 LED "ON" ADC - ATN, ADR, 80 - A/D**
 convert the blood sensor pad with the LED on.

DO CHANNEL 2 LED "OFF" ADC - ATN, ADR, 84 - A/D
 convert the blood sensor pad with the LED off.

30 **READ CHANNEL 1 ADC LED "ON" RESULT - ATN, ADR,**
 88 - Read result of last chemistry pad A/D conversion with the LED on. This is sent as a two byte number with the least significant byte first. It is sent as raw counts.

35 **WRITE CHANNEL 1 ADC "OFF" RESULT - ATN, ADR, 90**
 (nn) - Write to the reserved RAM area which is used to

-43-

store the 16 bit A/D chemistry pad conversion result with LED on.

READ CHANNEL 1 ADC "OFF" RESULT - ATN, ADR, 92

5 - Read result of last chemistry pad A/D conversion with the LED off. This is sent as a two byte number with the least significant byte first. It is sent as raw counts.

WRITE CHANNEL 1 ADC "OFF" RESULT - ATN, ADR, 94

10 (nn) - Write to the reserved RAM area which is used to store the 16 bit A/D chemistry pad conversion result with LED off. Send LSB first.

READ CHANNEL 2 ADC LED "ON" RESULT - ATN, ADR,

15 96 (nn) - Read result of last blood sensor pad A/D conversion with the LED on. This is sent as a two byte number with the least significant byte first. It is sent as raw counts.

WRITE CHANNEL 2 ADC LED "ON" RESULT - ATN, ADR,

98 (nn) - Write to the reserved RAM area which is used to store the 16 bit A/D blood sensor conversion result with the LED on. Send LSB first.

20 **READ CHANNEL 2 ADC LED "OFF" RESULT - ATN, ADR,**

100 - Read result of last blood sensor pad A/D conversion with the LED off. This is sent as a two byte number with the least significant byte first. It is sent as raw counts.

25 **WRITE CHANNEL 2 ADC LED "OFF" RESULT - ATN,**

ADR, 102 (nn) - Write to the reserved RAM area which is used to store the 16 bit A/D blood sensor conversion result with the LED off. Send LSB first.

ACKNOWLEDGE - ATN, ADR, 104 - Acknowledge. The

30 meter that has been addressed acknowledges its presence by echoing its device address. Sends one byte.

WRITE DEVICE ADDRESS - ATN, ADR, 110(n) - Write meter device address n>0, <256, not equal to 43. Changes the meter's device address.

35 **DO CHANNEL 1 REMISSION - ATN, ADR, 112 - Do a**

-44-

remission for channel 1, the chemistry pad channel. This request causes the meter to do an A/D conversion with the LED on and off and then calculate the remission.

READ INTERNAL EEPROM - ATN, ADR, 116 (nn) -

5 Read from the internal EEPROM. The first byte sent is the nibble address and the second byte is the count (n-1) of nibbles to read.

WRITE INTERNAL EEPROM - ATN, ADR, 118 (nn) -

10 Write to the internal EEPROM. The first byte sent is the nibble address and the second is the count (n-1) of nibbles to be written. If more than 8 bytes are required, then a separate command is required for each extra group of 8 bytes. It is necessary to retransmit the command for each group of 8 bytes.

15 **WRITE TO LCD - ATN, ADR, 126 (nnnnnnnnnn) -**

Write to the LCD. In addition, this command causes the meter to initialize the LCD and check battery voltage. The mapping of the bit sequence is as follows: 11 bytes of data must be sent. Each byte has a most significant (MS) nibble (bits 7 through 4) which is used as data in the address and segment map of Fig. 13. Each byte has a LS nibble (bits 3 through 0) which is used as the address in the address and segment map of Fig. 13. If a data bit is a 1, then that segment is darkened. If it is a 0, then the segment is not darkened. Data bit 7 of the address and segment map is not used.

SOUND BEEPER - ATN, ADR, 132 (nn) - Beep.

Causes the device to beep. The first byte determines the frequency and the second byte determines the duration.

30 **READ EXTERNAL EEROM - ATN, ADR, 144 (nn) - Read**

from the external code ROM key 64. The first byte sent is the nibble address and the second byte is the number of nibbles to read (n-1).

WRITE EXTERNAL EEROM - ATN, ADR, 146 (nn) -

35 Write to the external code ROM key 64. The first byte

-45-

sent is the nibble address and the second is the count (n-1) of nibbles to be written. If more than 8 bytes are required, then a separate command is required for each group of 8 bytes. It is necessary to retransmit the
5 command for each group of 8 bytes.

DO LAMBDA AND READ "RPRIME" - ATN, ADR, 148 -
This causes a new RPRIME (wavelength correction) to be generated. Then RPRIME is sent out the serial port in floating point format.

10 **WRITE "RPRIME" - ATN, ADR, 150 -** This writes a floating point number to the position pointed to by "RPRIME".

TURN OFF THE METER - ATN, ADR, 152 - Turn off the meter 10. This causes the meter 10 to turn off,
15 readying it for use.

DO CHANNEL 2 REMISSION - ATN, ADR, 156 - Do a complete remission for channel 2. This causes the meter to do an A/D conversion with the LED on and off and calculate the remission.

20 **DO A STRIP DETECTION/REACTION ASSESSMENT - ATN, ADR, 160 -** This request causes the meter to detect an inserted strip and to calculate the remission per the reaction assessment module which includes end of reaction. Remissions will be transmitted out the port if
25 the TRACE flag is set. Following the completion of the end of reaction (EOR) assessment, the following information is transmitted in the order listed below:

30 1 byte = number of comparisons performed during EOR
4 bytes = IR channel remission following EOR
4 bytes = the final remission taken at the end of
EOR (EORREM)
2 bytes = CRC of the above 9 bytes

35 **CALCULATE AND READ GLUCOSE - ATN, ADR, 164 -**

-46-

Calculate a glucose concentration from the value in RAM called RPRIME. The remission value is passed through the math routine to generate a glucose value. A four byte floating point format number is returned over the serial port. The number is glucose concentration in mg/dL. If the glucose concentration is found to be too low (LO) for the meter 10 to detect accurately, then a 1 is returned. If the glucose concentration is found to be too high (HI) for the meter 10 to detect accurately, then a 1000 is returned.

5

10

15

20

25

30

35

DO A BATTERY CONVERSION - ATN, ADR, 168 - Do a conversion of the battery voltage. The result is then transmitted out as 1 byte.

DO A CH1 LOW POWER ADC WITH LED ON - ATN, ADR, 172 - Do a low power A/D conversion on channel 1 with LED on.

DO A CH1 LOW POWER ADC WITH LED OFF - ATN, ADR, 176 - Do a low power A/D conversion on channel 1 with LED off.

READ CH1 LOW POWER ON RESULT - ATN, ADR, 180 - Read the channel 1 low power LED on result.

WRITE CH1 LOW POWER LED ON RESULT - ATN, ADR, 182 (nn) - Write the 16 bit unsigned integer channel 1 low power LED on result.

READ CH1 LOW POWER LED OFF RESULT - ATN, ADR, 184 - Read the channel 1 low power LED off result.

WRITE CH1 LOW POWER LED OFF RESULT - ATN, ADR, 186 (nn) - Write the channel 1 low power LED off result.

READ CH1 LOW POWER LED ON TIME - ATN, ADR, 188 - Read the channel 1 low power LED on time.

WRITE CH1 LOW POWER LED ON TIME - ATN, ADR, 190 (n) - Write the channel 1 low power LED on time.

READ CH1 SECOND ORDER VALUE - ATN, ADR, 192 - Read the channel 1 second order term. The number is sent out in floating point format.

-47-

WRITE CH1 SECOND ORDER VALUE - ATN, ADR, 194
(nnnn) - Write the channel 1 second order value. The four byte number is sent out in floating point format.

READ CH2 SECOND ORDER VALUE - ATN, ADR, 196 -
5 Read the channel 2 second order value. The 4 byte number is sent out in floating point format.

WRITE CH2 SECOND ORDER VALUE - ATN, ADR, 198
(nnnn) - Write the channel 2 second order value. The 4 byte number is sent out in floating point format.

10 **DO CHANNEL 1 SCALE - ATN, ADR, 200 -** Do a channel 1 scale. This causes the meter to take a remission reading and to use this to generate a new slope.

15 **DO CHANNEL 2 SCALE - ATN, ADR, 204 -** Do a channel 2 scale. This causes the meter to take a remission reading and to use this to generate a new slope.

20 **READ "DISPLAY" - ATN, ADR, 208 -** The variable DISPLAY is returned over the serial port in a 16 bit format.

WRITE DISPLAY WORD AND DISPLAY IT - ATN, ADR, 210 - This accepts a 16 bit word over the serial port and writes it to the location pointed to by DISPLAY and displays it on the LCD.

25 **DO CHANNEL 2 LIGHT/DARK READING - ATN, ADR, 212 -** This causes the meter to do a channel 2 (IR channel) A/D conversion with the LED on followed by an A/D conversion with the led off.

30 **DO LOW POWER CHANNEL 1 LIGHT/DARK READING -**
ATN, ADR, 216 - This causes the meter to do a channel 1 low power A/D conversion with the LED on followed by an LED off reading.

35 **READ THE REVISION NUMBER - ATN, ADR, 220 -** This causes the meter to output a byte which is the revision number of the internal software.

5 **DO A STRIP INSERTION - ATN, ADR, 224 -** This causes the meter to sample the strip detection algorithm every .5 second until a strip is detected. At this time the meter will output a byte of data in the following format:

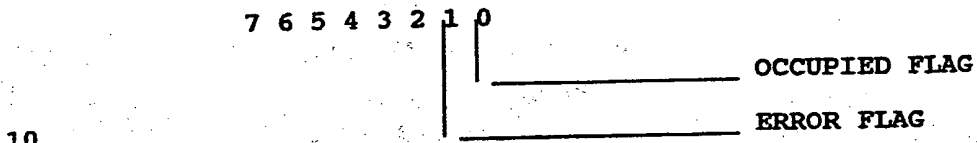

15 **DO A CHANNEL 1 LIGHT/DARK ADC - ATN, ADR, 228 -** This causes the meter to do a normal power A/D conversion on channel 1 with the LED on followed by one with the LED off.

20 **READ "BORREM 1" - ATN, ADR, 232 -** This reads a floating point format number called BORREM1. This number is used to calculate RPRIME.

RESERVED FOR ENGINEERING USE - ATN, ADR, 234 - This writes a floating point format number to the meter as BORREM1. This is the number used by function LAMBDA to calculate RPRIME.

Claims:

1. A method of communicating with one or more microcomputer controlled instruments for determining the concentration of a medically significant component of a body fluid, each instrument including a port through which instructions and data can be received from, and transmitted to, an external device, the method comprising the steps of transmitting to each instrument an attention protocol for advising each instrument that a further instruction is to be transmitted, transmitting one of a global address to all of such instruments and an address unique to one of such instruments, and transmitting an instruction to all or said one instrument.
2. The method of claim 1 wherein the step of transmitting the attention protocol comprises one of the step of transmitting a first attention protocol if the instruments are activated and in a state in which they are capable of determining the concentration of the medically significant component and the step of transmitting a second attention protocol if the instruments are inactivated and not in a state in which they are capable of determining the concentration of the medically significant component.
3. The method of claim 1 wherein the step of transmitting an instruction comprises the step of transmitting one of a command and a request, and further comprising the step of transmitting a key for permitting the instrument or instruments addressed to respond to the command.
4. The method of claim 3 wherein the steps of transmitting a key and a command together comprise the step of first transmitting the key for permitting the instrument or instruments addressed to receive the command and then transmitting the command for causing the

-50-

instrument or instruments addressed to respond to the command.

5 5. The method of claim 1 wherein the instrument includes a programmable non-volatile memory and the instruction comprises instrument calibration information for storage in the non-volatile memory.

10 6. The method of claim 5 and further comprising the steps of reading the calibration information from the non-volatile memory, comparing that information to information contained in a volatile memory in the microcomputer, and generating an error message in response to an unfavorable comparison.

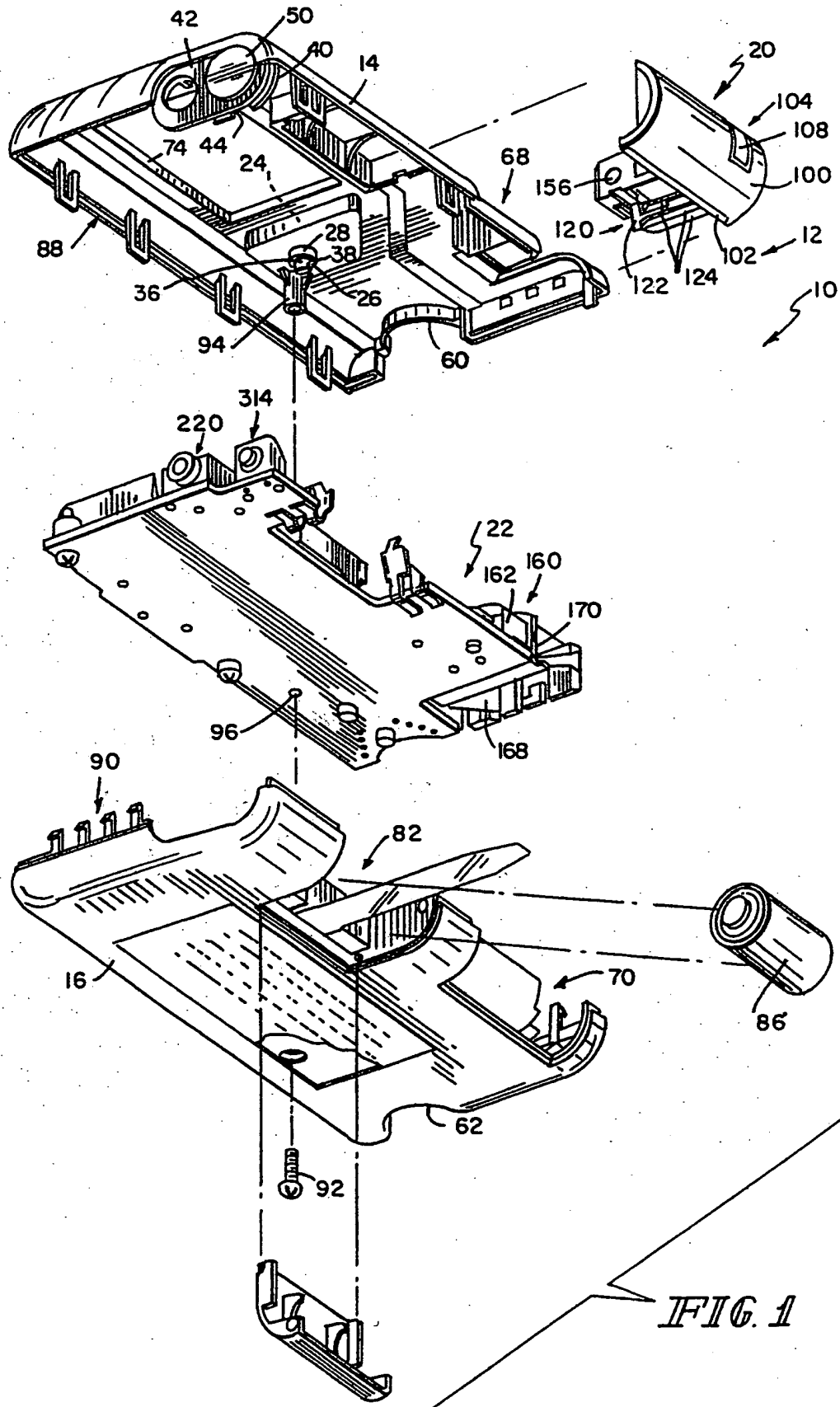

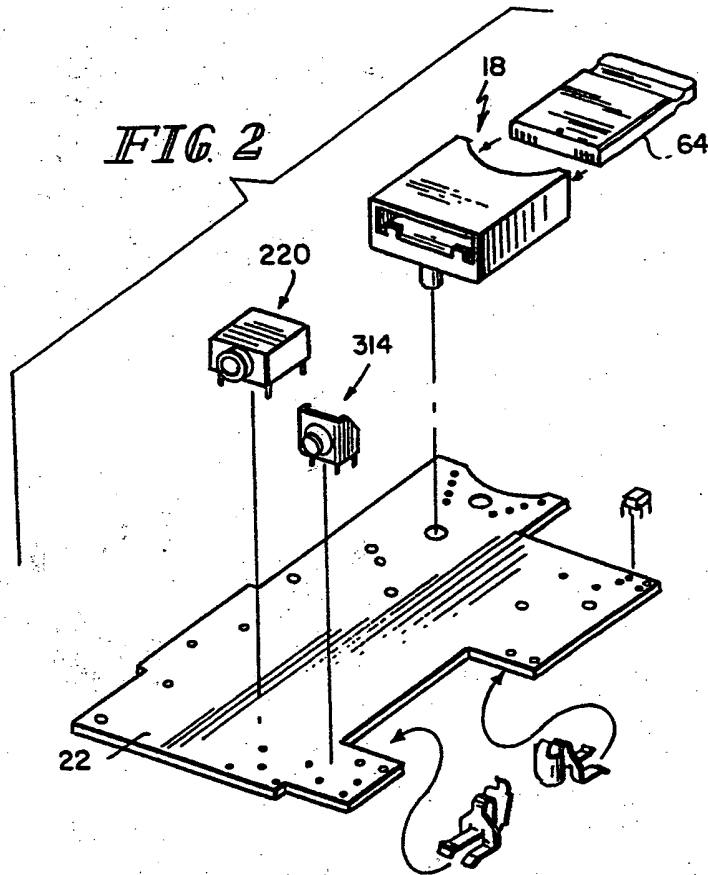

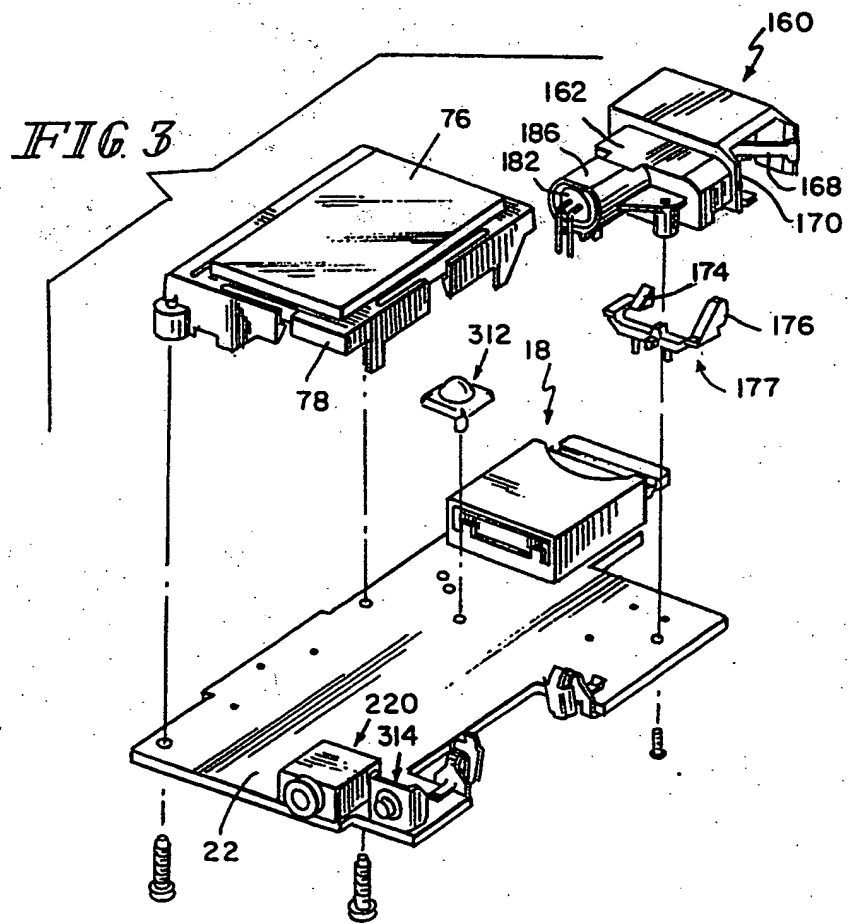

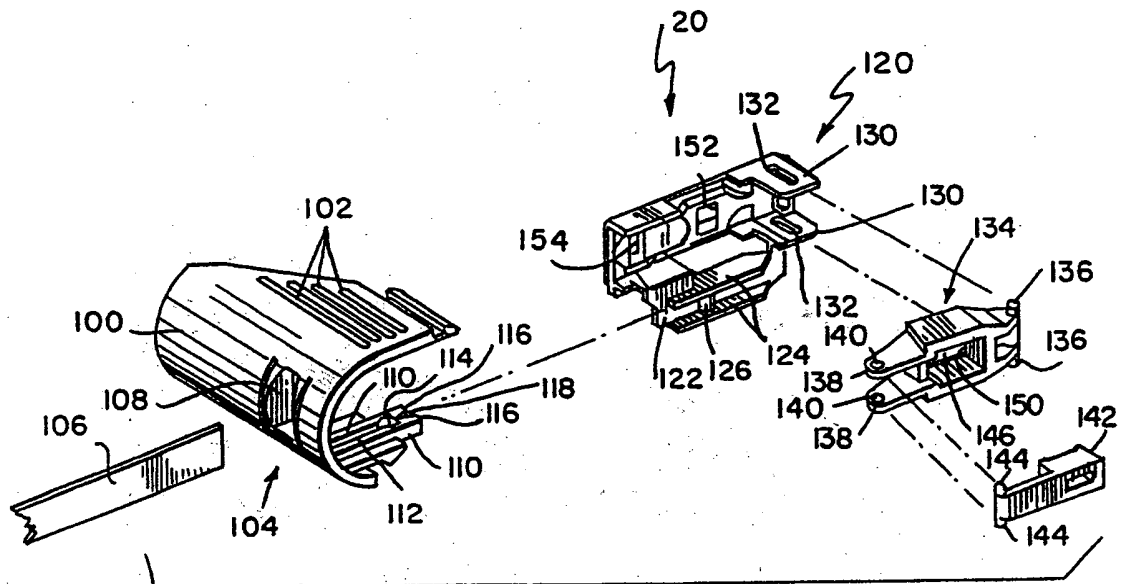

FIG. 4

FIG. 5

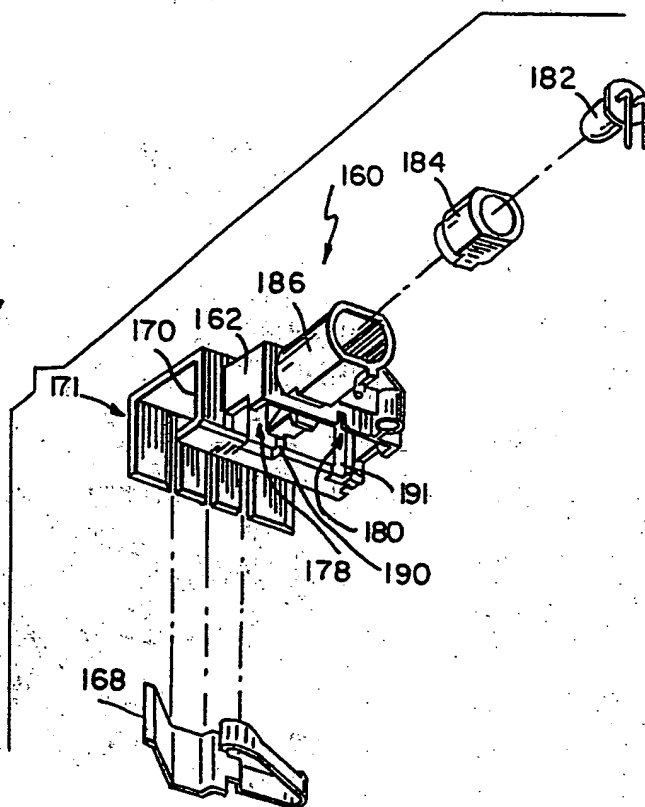
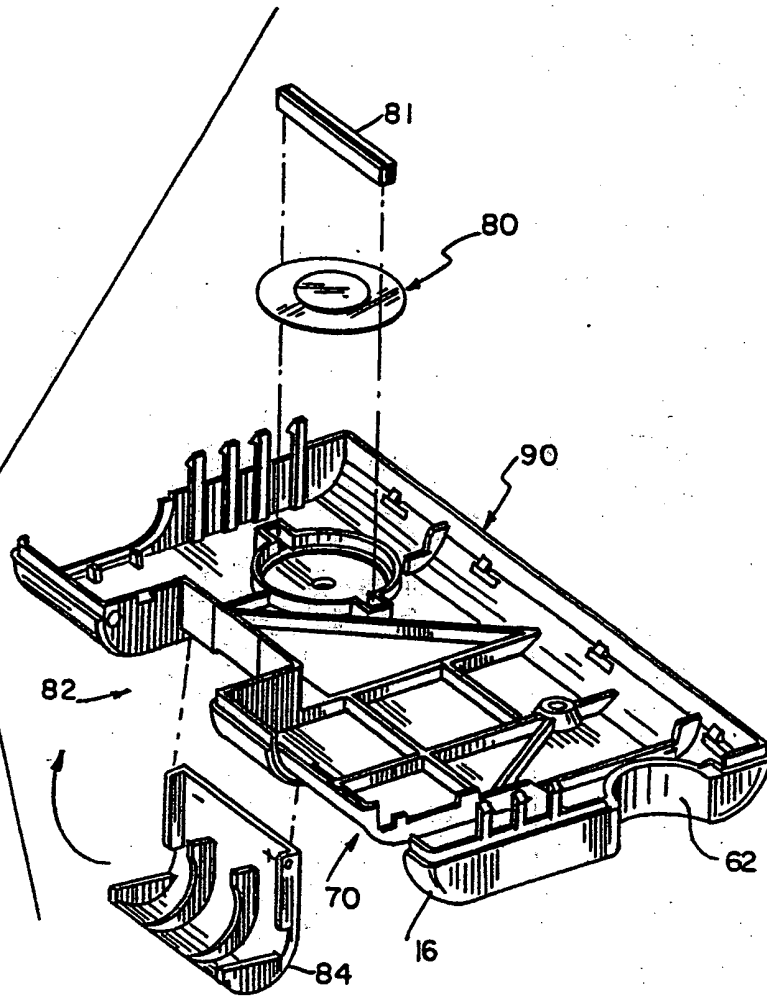
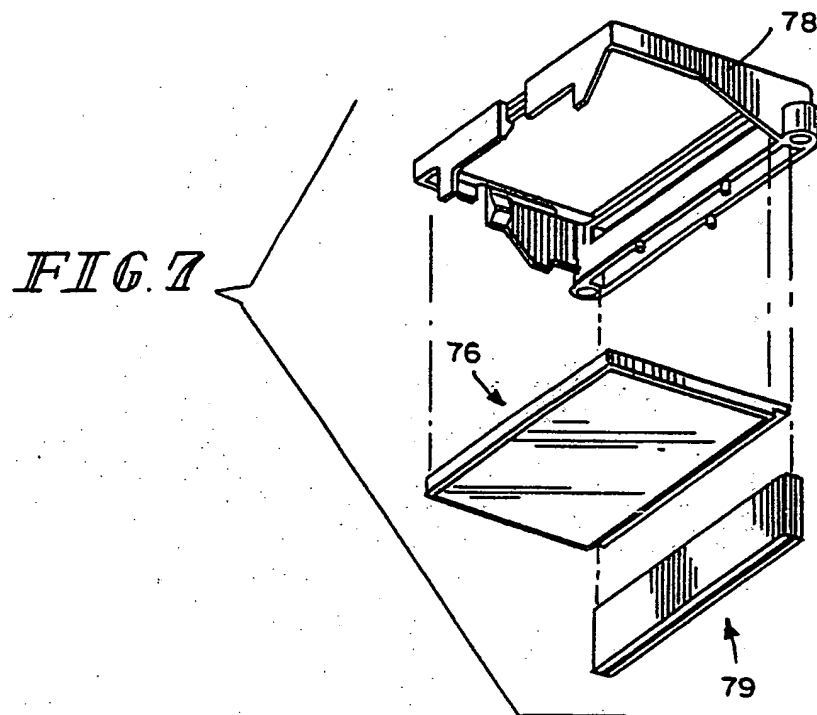

FIG. 6





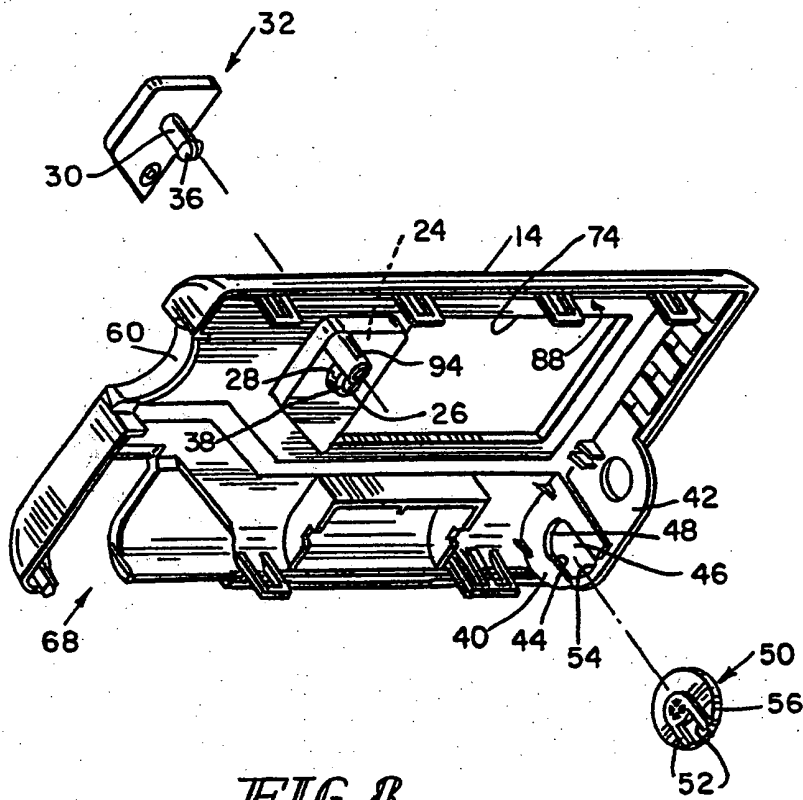

FIG. 8

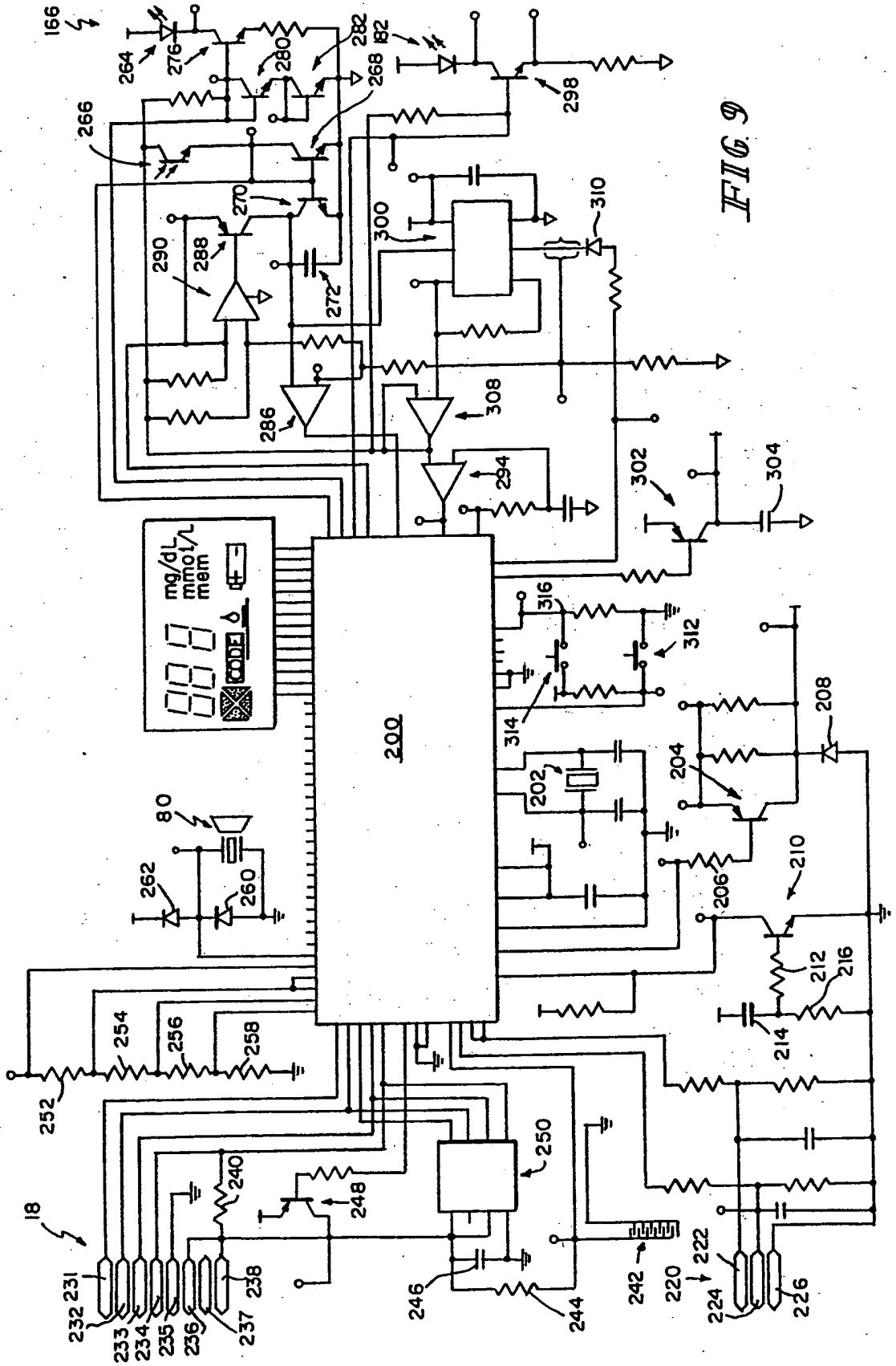

FIG 9

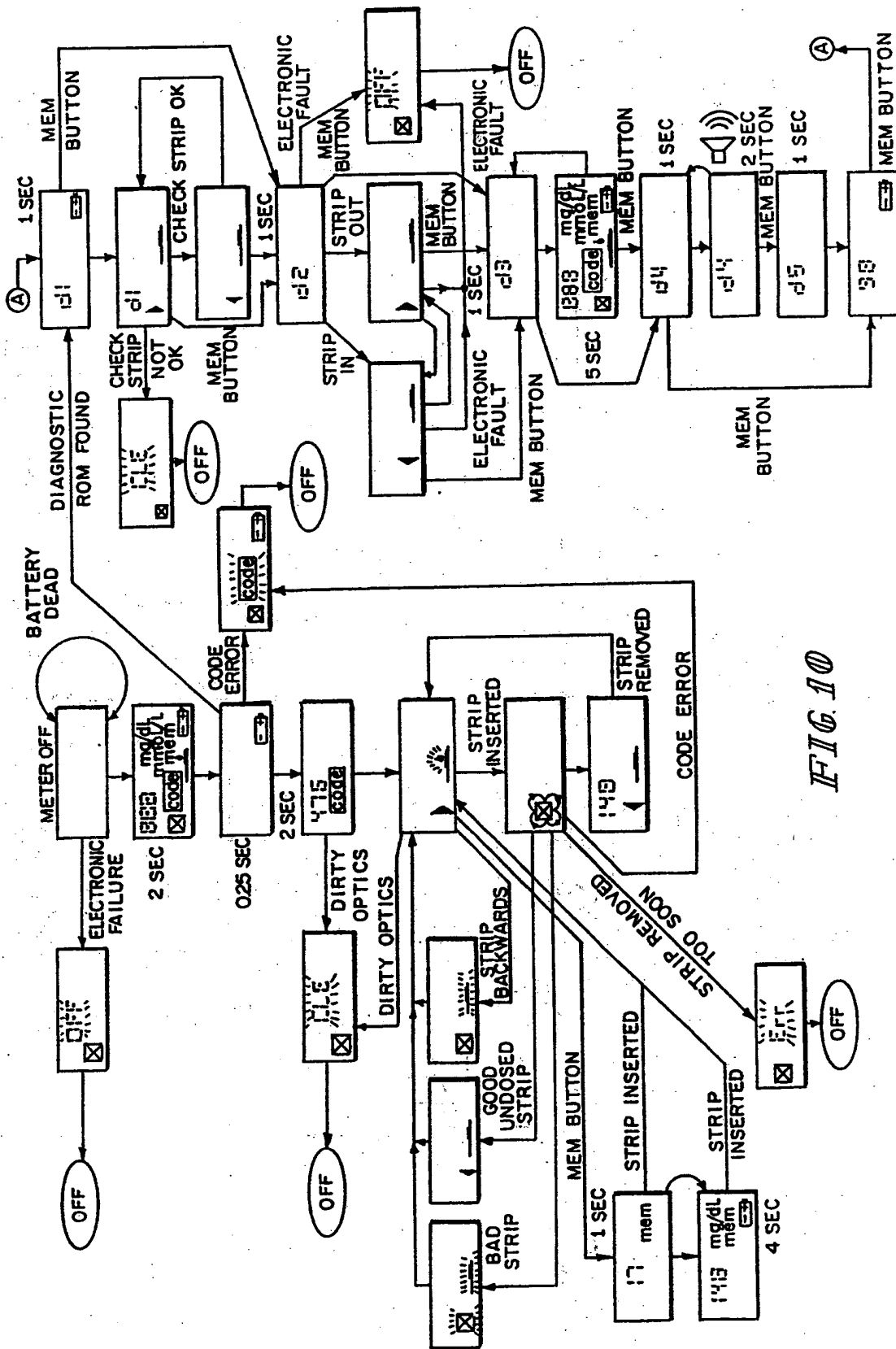
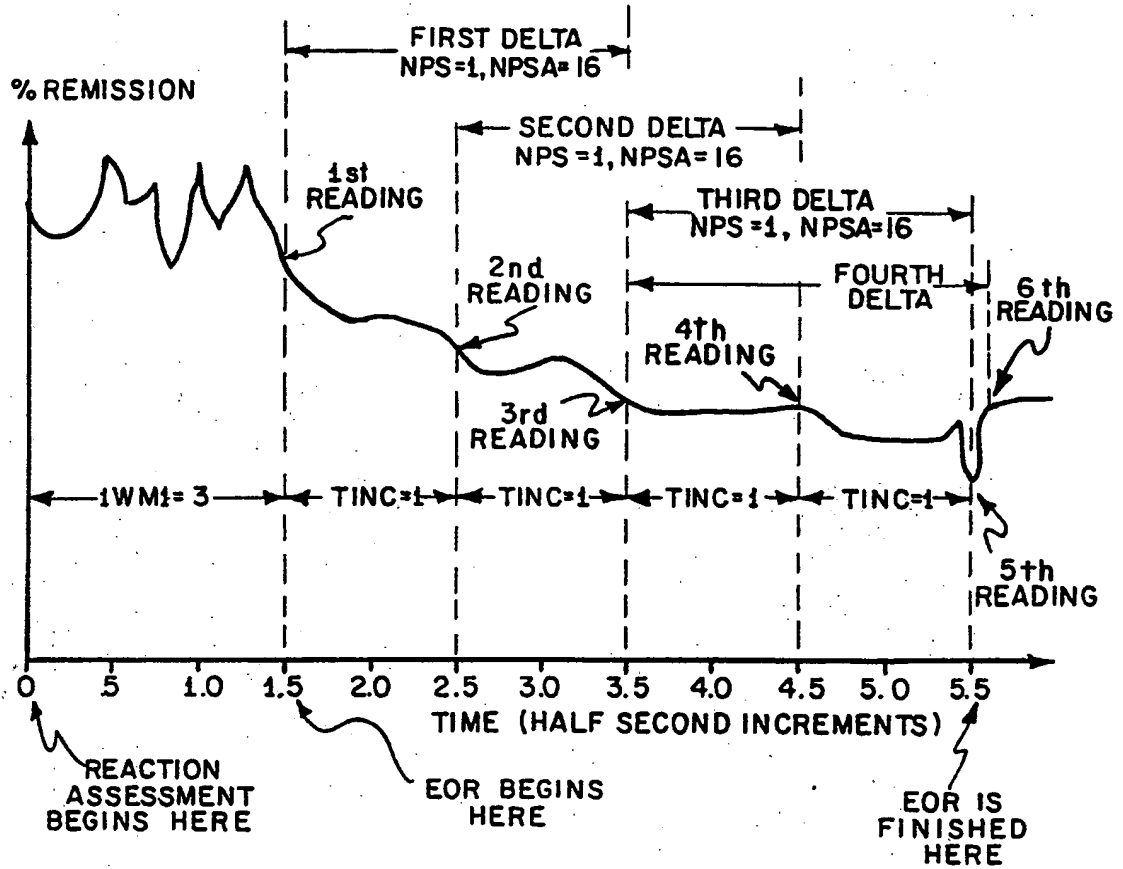

FIG 10

11/13



I WMA > 2
ERS = 1 OR 0
EORCOUNT = 2
MAX_F = 0
TOTAL NUMBER OF REMISSIONS TAKEN = 5
EORREM:1 RECEIVES THE 5TH READING

FIG. 11

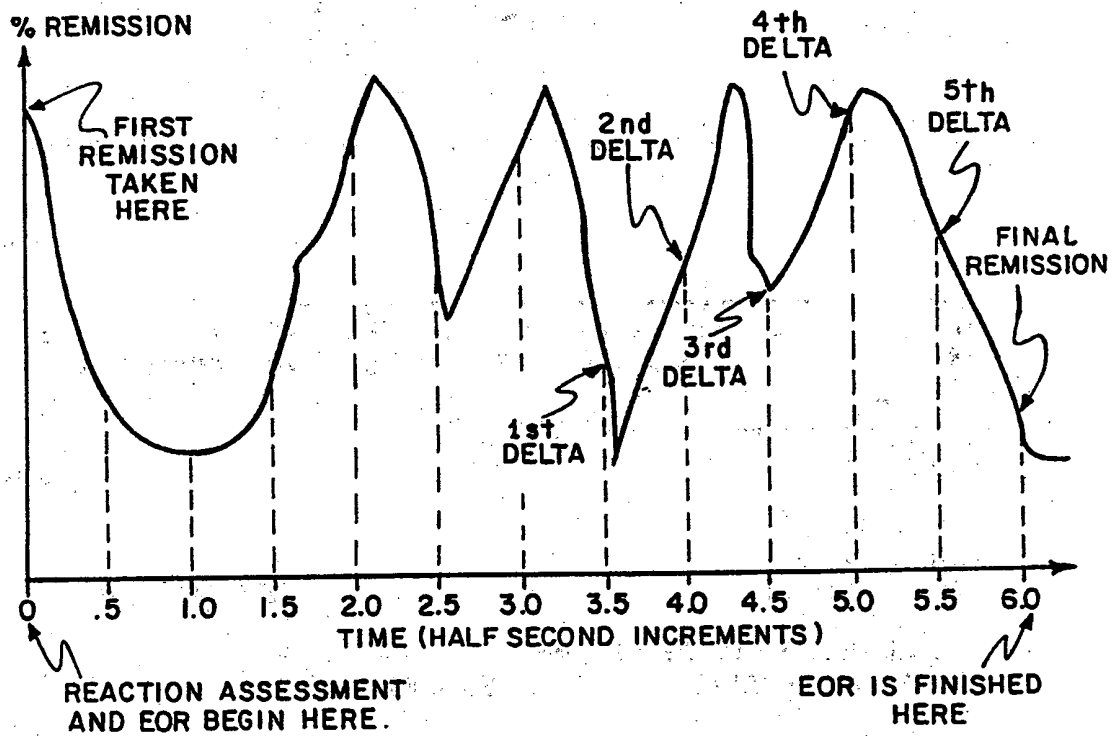

IWMA = 5
ERS = 1
EORCOUNT = 5
MAX_F = 1
TOTAL NUMBER OF REMISSIONS TAKEN = 13
EORREMI RECEIVES THE 13th READING

TINC = 0
IWMI = 0
NPS = 6
NPSA = 56

FIG. 12





























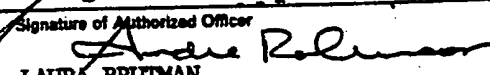
| PROJECT 403 LCD ADDRESS AND SEGMENT | | | | |
|-------------------------------------|--------------|---|---|---|
| ADDRESS BITS 3-0 | DATA BIT7 | DATA BIT6 | DATA BIT5 | DATA BIT4 |
| 0H | |  |  | CODE |
| 1H | | mg/dl | mmol/l | mem |
| 2H | |  |  |  |
| 3H | |  |  |  |
| 4H | |  |  |  |
| 5H | |  |  |  |
| 6H | |  |  |  |
| 7H | |  |  |  |
| 8H | |  |  |  |
| 9H | |  |  |  |
| AH | |  |  |  |

FIG. 13

INTERNATIONAL SEARCH REPORT

International Application No. **PCT/US92/01631**

| | | |
|--|--|-------------------------------------|
| I. CLASSIFICATION OF SUBJECT MATTER (If several classification symbols apply, indicate all) ⁶ | | |
| According to International Patent Classification (IPC) or to both National Classification and IPC | | |
| IPC(5): G06F 15/00 | | |
| II. FIELDS SEARCHED | | |
| Minimum Documentation Searched ⁷ | | |
| Classification System | Classification Symbols | |
| U.S. | 364/413.01, 413.07, 413.11 | |
| Documentation Searched other than Minimum Documentation to the Extent that such Documents are Included in the Fields Searched ⁸ | | |
| III. DOCUMENTS CONSIDERED TO BE RELEVANT ⁹ | | |
| Category ⁹ | Citation of Document, ¹¹ with indication, where appropriate, of the relevant passages ¹² | Relevant to Claim No. ¹³ |
| Y | US, A, 4,093,849 (BAXTER) 06 June 1978, See column 41, line 9; column 41, line 11- column 42, line 2. | 1-6 |
| A | US, A, 4,168,469 (PARIKH) 18 September 1979, See the entire document. | 1-6 |
| A | US, A, 4,747,060 (SEARS, III) 24 May 1988, See the entire document. | 1-6 |
| A | US, A, 4,751,648 (SEARS, III) 14 June 1988, See the entire document. | 1-6 |
| Y | US, A, 4,791,570 (SHERMAN) 13 December 1988, See the entire document. | 1-6 |
| Y | US, A, 4,882,704 (KOMORI) 21 November 1989, See claims 4 and 14. | 1-6 |
| A | US, A, 4,882,705 (YASUE) 21 November 1989, See the entire document. | 1-6 |
| Y | US, A, 4,902,948 (SHERMAN) 20 February 1990, See the entire document. | 1-6 |
| <p>¹⁰ Special categories of cited documents:</p> <p>"A" document defining the general state of the art which is not considered to be of particular relevance</p> <p>"E" earlier document but published on or after the international filing date</p> <p>"L" document which may throw doubts on priority claim(s) or which is cited to establish the publication date of another citation or other special reason (as specified)</p> <p>"O" document referring to an oral disclosure, use, exhibition or other means</p> <p>"P" document published prior to the international filing date but later than the priority date claimed</p> <p>"T" later document published after the international filing date or priority date and not in conflict with the application but cited to understand the principle or theory underlying the invention</p> <p>"X" document of particular relevance; the claimed invention cannot be considered novel or cannot be considered to involve an inventive step</p> <p>"Y" document of particular relevance; the claimed invention cannot be considered to involve an inventive step when the document is combined with one or more other such documents, such combination being obvious to a person skilled in the art.</p> <p>"A" document member of the same patent family</p> | | |
| IV. CERTIFICATION | | |
| Date of the Actual Completion of the International Search | Date of Mailing of this International Search Report | |
| 23 APRIL 1992 | 30 JUN 1992 | |
| International Searching Authority | Signature of Authorized Officer | |
| ISA/US |  LAURA BRUTMAN | |